

# LED Control board

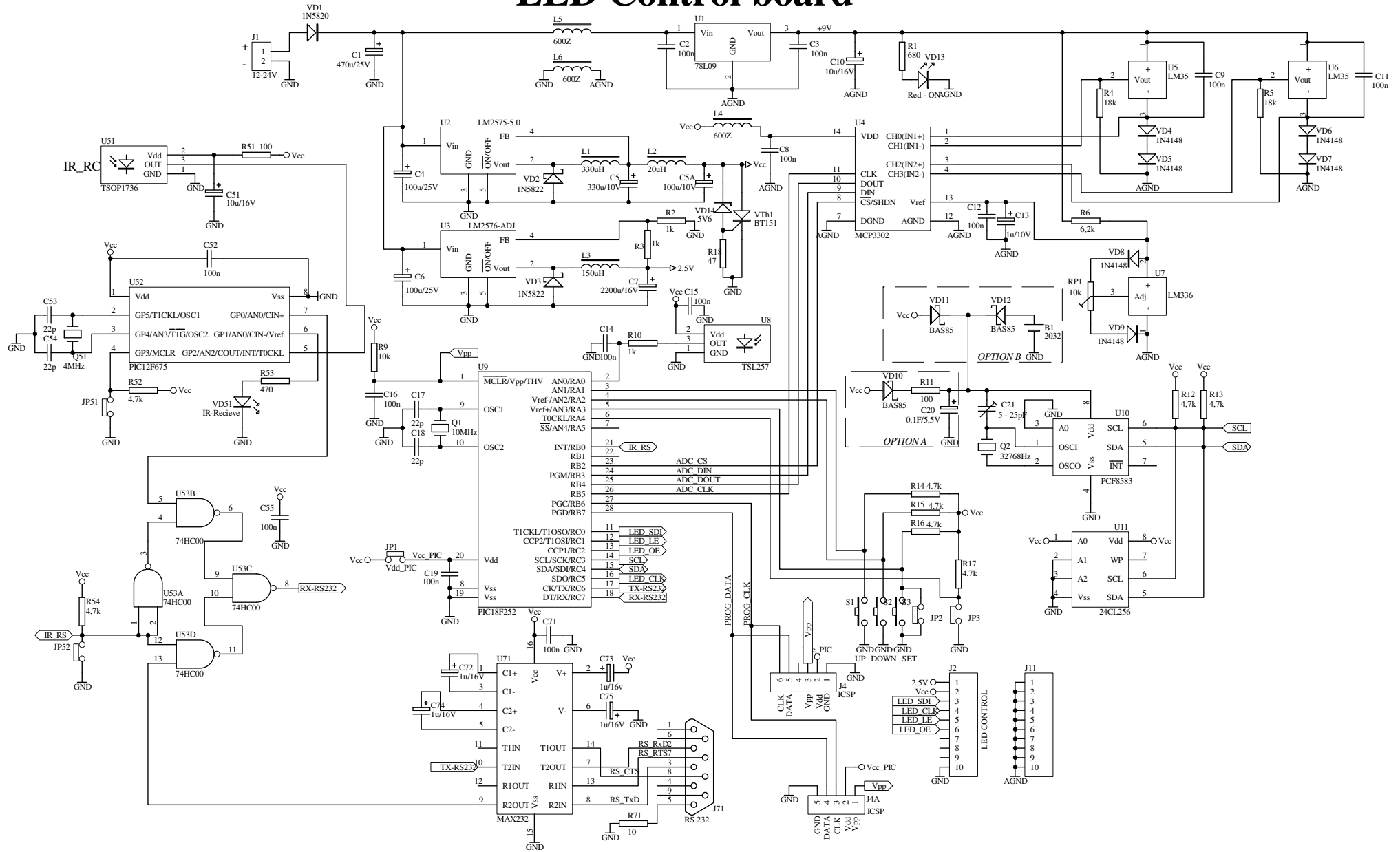

# LED Display board

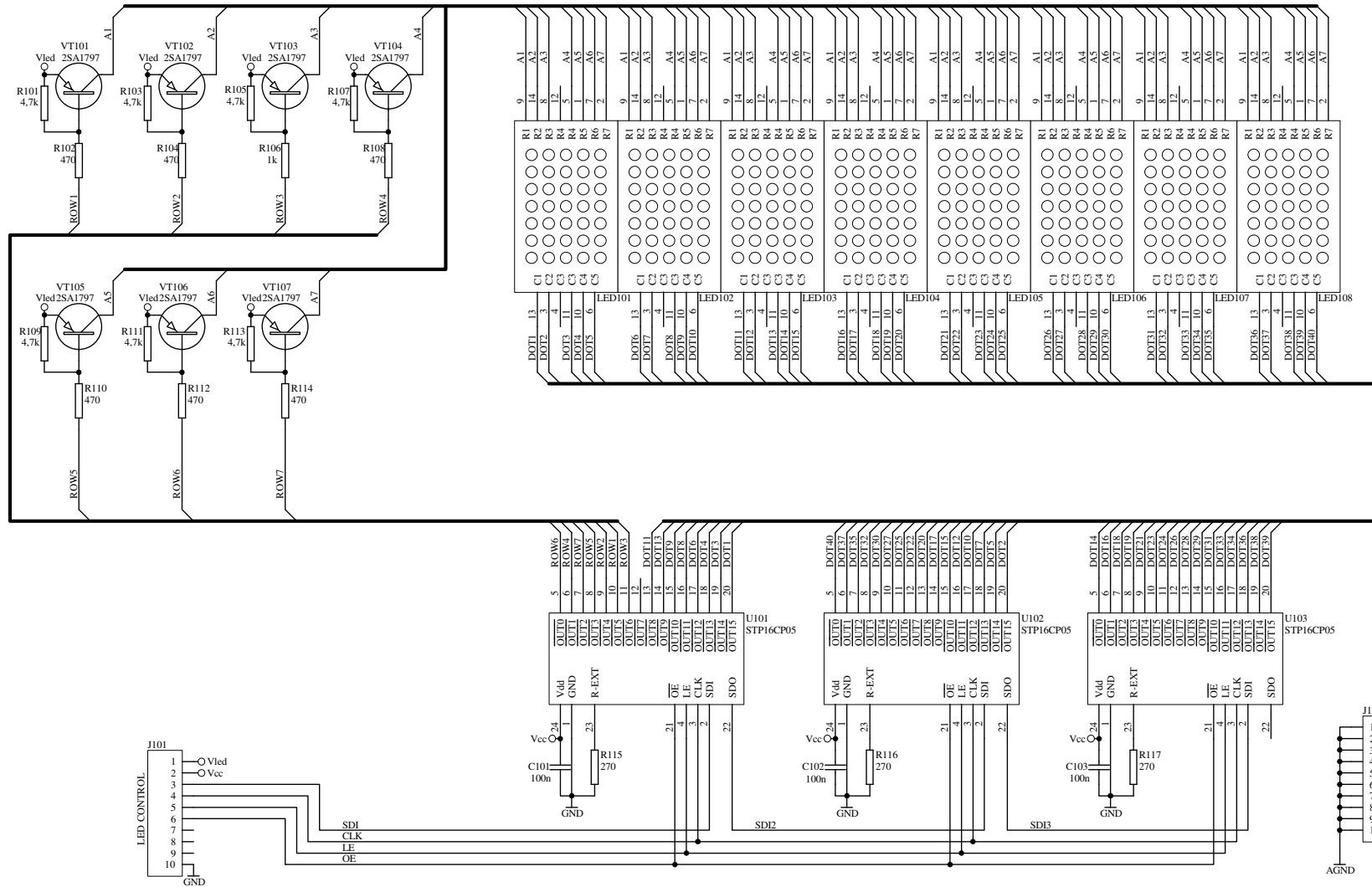

# LED Control board Top Layer

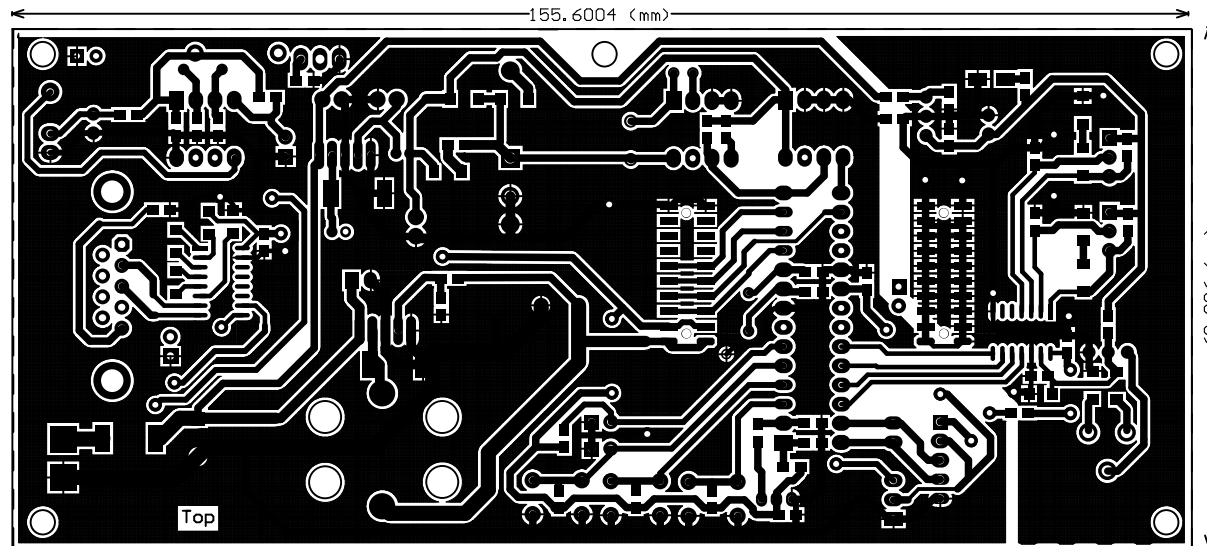

# LED Control board Bottom Layer

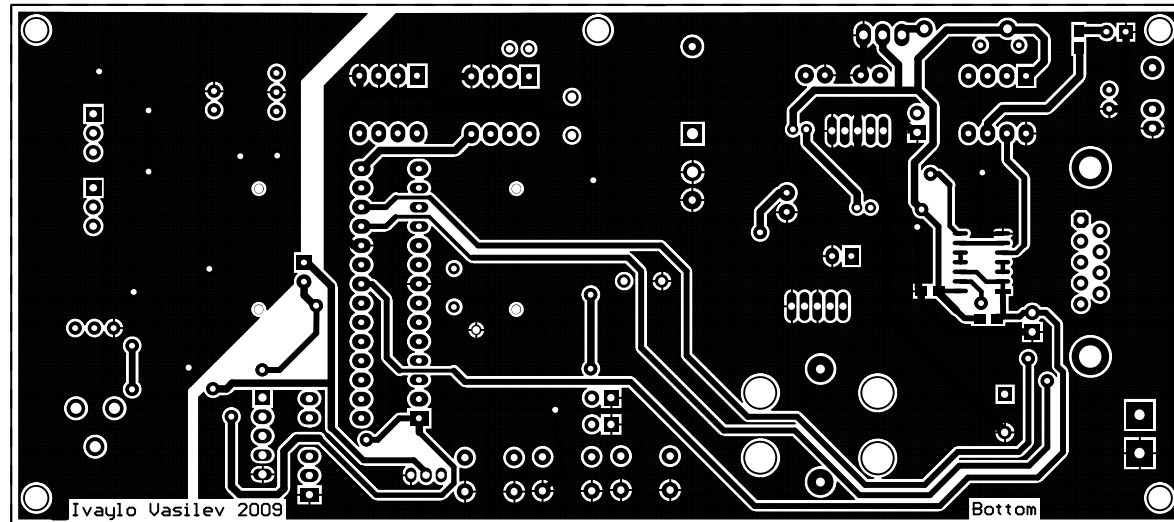

# LED Control board Top Components

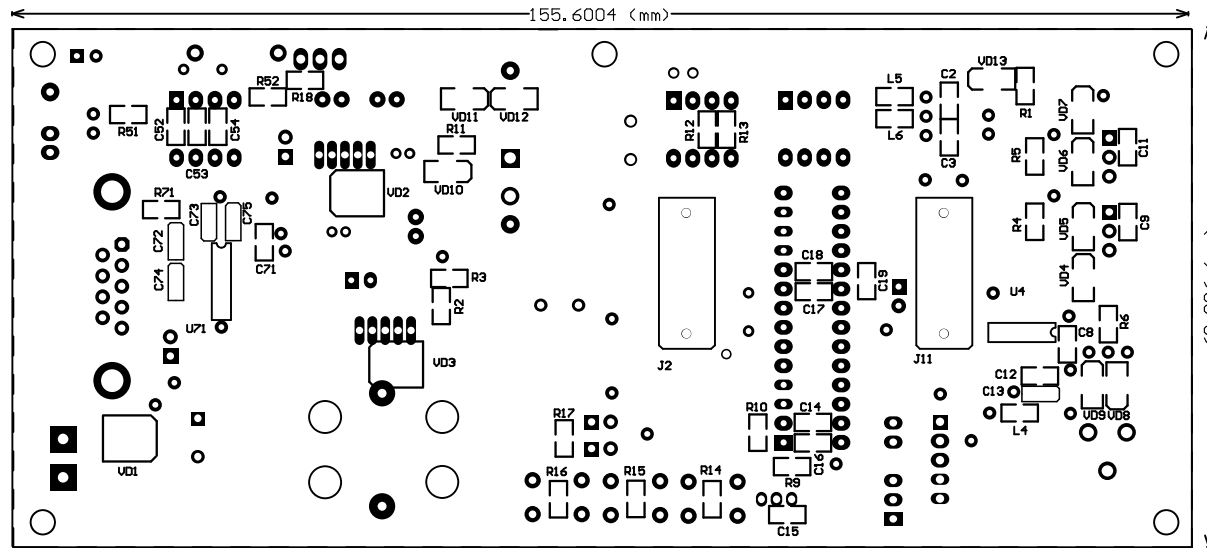

# LED Control board Bottom Components

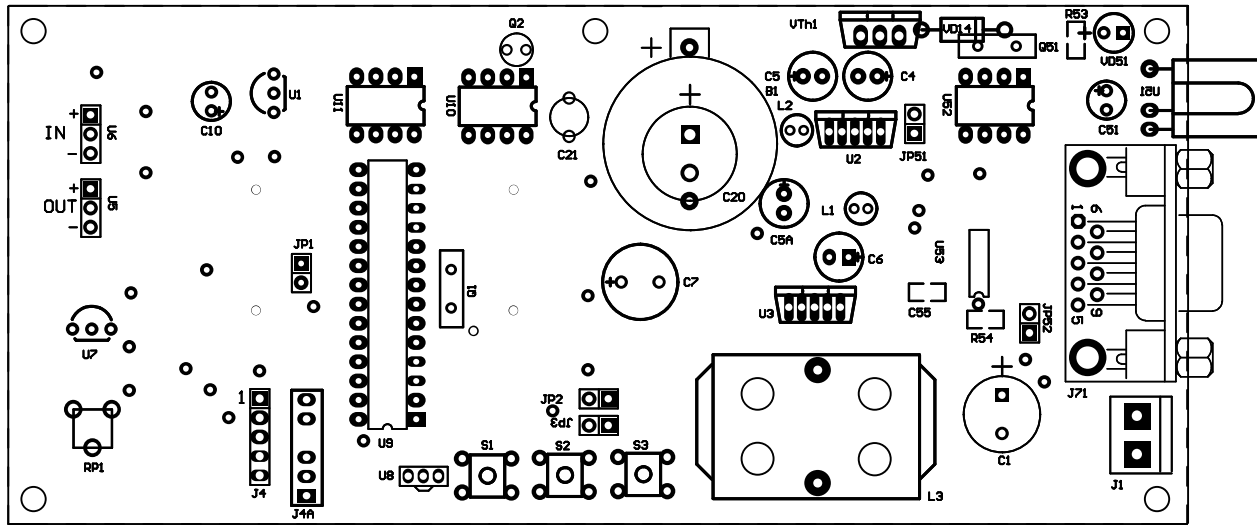

# LED Display board Top Layer (scaled: 3:4)

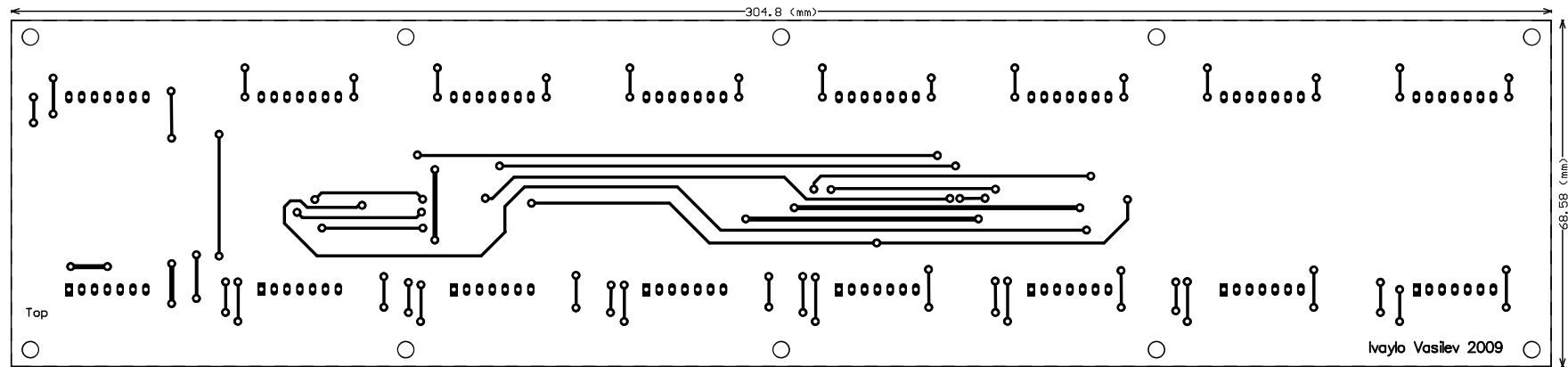

# LED Display board Bottom Layer (scaled: 3:4)

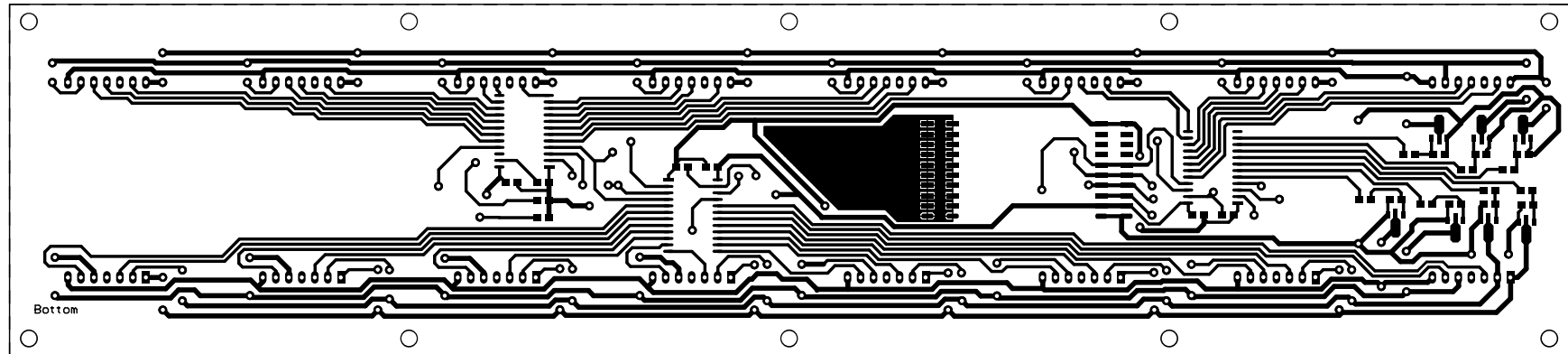

# LED Display board Top Components (scaled: 3:4)

