

1.2V TO 35V OUT PUT ADJUSTABLE DC-DC CONVERTER

1.2V to 35V Adjustable DC-DC Converter project has been design around TI LM2576-ADJ IC.

- Input supply 40 VDC
- Output 1.2 to 35 VDC @ 3 Amps regulated low ripple DC voltage
- Onboard potentiometer for output voltage adjust
- Onboard bridge rectifier for AC voltage input
- LED indication at input
- Terminal block connectors for input and output connection
- Heat Sink includes
- Four mounting holes of 3.2 mm each
- PCB dimensions 70 mm x 63 mm



Applications :

- Table Top Power Supply
- Lab Power Supply
- Automotive
- Battery Operated Equipment
- Amusement Rides

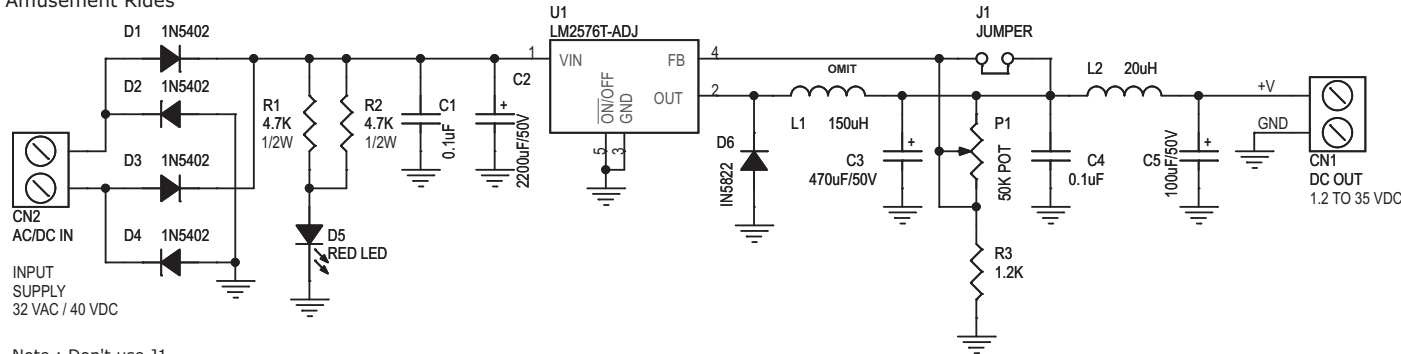

Note : Don't use J1

SR.	QTY.	REF.	DESCRIPTION
1	1	CN1	2 PIN TERMINAL BLOCK CONNECTOR
2	1	CN2	2 PIN TERMINAL BLOCK CONNECTOR
3	2	C1,C4	0.1uF
4	1	C2	2200uF/50V
5	1	C3	470uF/50V
6	1	C5	100uF/50V
7	4	D1,D2,D3,D4	1N5402/1N5408
8	1	D5	RED LED
9	1	D6	1N5822
10	1	J1	OMIT
11	1	L1	150uH INDUCTOR
12	1	L2	20uH INDUCTOR
13	1	P1	47K/50K POT
14	2	R1,R2	4.7K, 0.5W
15	1	R3	1.2K
16	1	U1	LM2576T-ADJ
17	1	HEATSINK	HS05025
18	3	SCREW	SC02905
19	1	NUT	NT02900

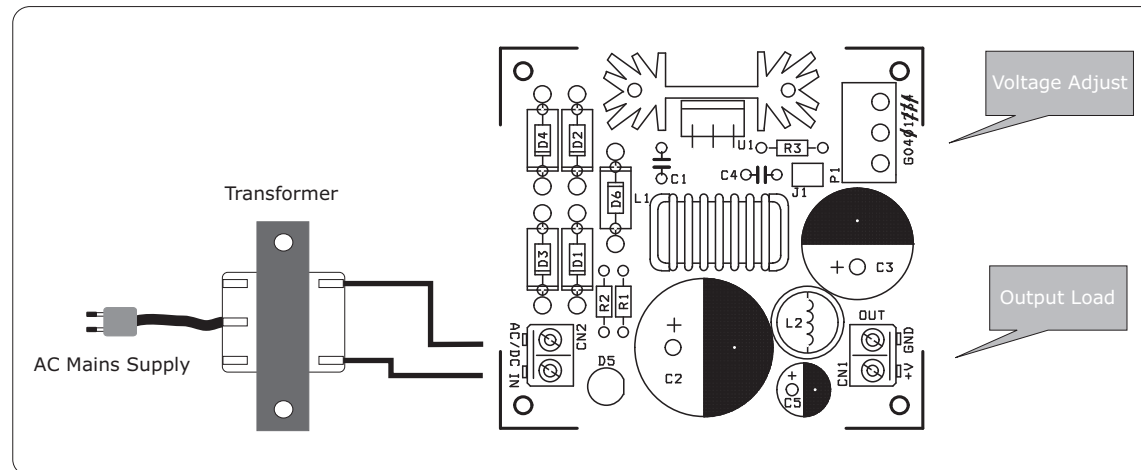

1.2V TO 35V OUT PUT ADJUSTABLE DC-DC CONVERTER

