

## PWM SOLENOID/VALVE DRIVER

### FEATURES

- **HIGH OUTPUT DRIVE: 2.3A**
- **WIDE SUPPLY RANGE: +9V to +60V**
- **COMPLETE FUNCTION**
  - PWM Output
  - Internal 24kHz Oscillator
  - Digital Control Input
  - Adjustable Delay and Duty Cycle
  - Over/Under Current Indicator
- **FULLY PROTECTED**
  - Thermal Shutdown with Indicator
  - Internal Current Limit
- **PACKAGES: 7-Lead TO-220 and 7-Lead Surface-Mount DPAK**

### APPLICATIONS

- **ELECTROMECHANICAL DRIVER:**
  - Solenoids      Positioners
  - Actuators      High Power Relays/Contactors
  - Valves          Clutch/Brake
- **FLUID AND GAS FLOW SYSTEMS**
- **INDUSTRIAL CONTROL**
- **FACTORY AUTOMATION**
- **PART HANDLERS**
- **PHOTOGRAPHIC PROCESSING**
- **ELECTRICAL HEATERS**
- **MOTOR SPEED CONTROL**
- **SOLENOID/COIL PROTECTORS**
- **MEDICAL ANALYZERS**

### DESCRIPTION

The DRV101 is a low-side power switch employing a pulse-width modulated (PWM) output. Its rugged design is optimized for driving electromechanical devices such as valves, solenoids, relays, actuators, and positioners. The DRV101 is also ideal for driving thermal devices such as heaters and lamps. PWM operation conserves power and reduces heat rise, resulting in higher reliability. In addition, adjustable PWM allows fine control of the power delivered to the load. Time from dc output to PWM output is externally adjustable.

The DRV101 can be set to provide a strong initial closure, automatically switching to a “soft” hold mode for power savings. Duty cycle can be controlled by a resistor, analog voltage, or digital-to-analog converter for versatility. A flag output indicates thermal shutdown and over/under current limit. A wide supply range allows use with a variety of actuators.

The DRV101 is available in 7-lead staggered TO-220 package and a 7-lead surface-mount DPAK plastic power package. It is specified over the extended industrial temperature range,  $-40^{\circ}\text{C}$  to  $+85^{\circ}\text{C}$ .

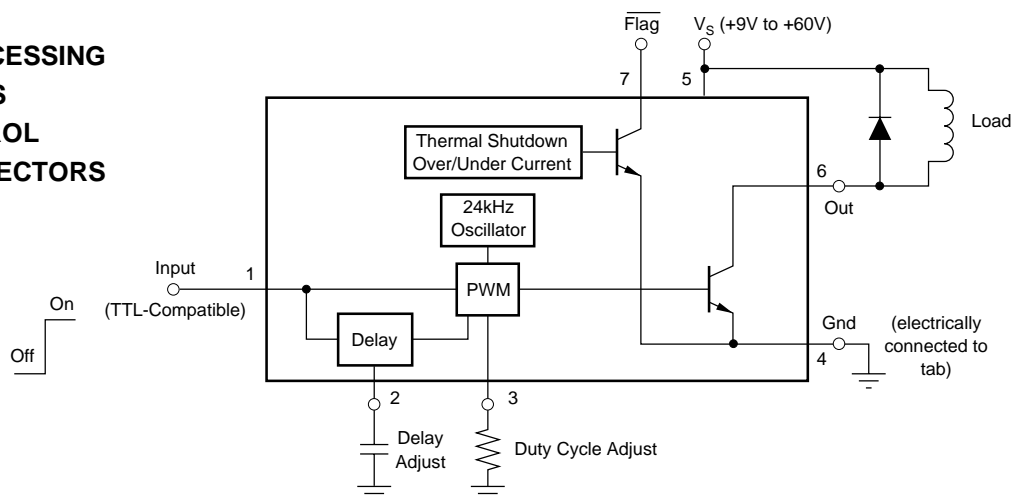

Please be aware that an important notice concerning availability, standard warranty, and use in critical applications of Texas Instruments semiconductor products and disclaimers thereto appears at the end of this data sheet.

All trademarks are the property of their respective owners.

# SPECIFICATIONS

At  $T_C = +25^\circ\text{C}$ ,  $V_S = +24\text{V}$ , Load =  $100\Omega \parallel 1000\text{pF}$ , and  $4.99\text{k}\Omega \overline{\text{Flag}}$  pullup to +5V, unless otherwise noted.

PARAMETER	COMMENTS	DRV101T, F			UNITS
		MIN	TYP	MAX	
<b>OUTPUT</b> Output Saturation Voltage, Sink Current Limit Under-Scale Current <sup>(1)</sup> Leakage Current	$I_O = 1\text{A}$ $I_O = 0.1\text{A}$  Output Transistor Off, $V_S = V_O = +60\text{V}$		+0.8 +0.2 2.3 23 $\pm 0.01$	+1 +0.3 3  $\pm 1$	V V A mA mA
<b>DIGITAL CONTROL INPUT<sup>(2)</sup></b> $V_{CTR}$ Low (output disabled) $V_{CTR}$ High (output enabled) $I_{CTR}$ Low (output disabled) $I_{CTR}$ High (output enabled) Propagation Delay	$V_{CTR} = 0\text{V}$ $V_{CTR} = +5\text{V}$ On-to-Off and Off-to-On	0 +2.2	-80 20 2	+1.2 +5.5	V V $\mu\text{A}$ $\mu\text{A}$ $\mu\text{s}$
<b>DELAY TO PWM<sup>(3)</sup></b> Delay Equation <sup>(4)</sup> Delay Time Minimum Delay Time <sup>(5)</sup>	dc to PWM Mode  $C_D = 0.1\mu\text{F}$ $C_D = 0$			Delay to PWM = $C_D \cdot 10^6$ ( $C_D$ in F) 80 95 15 110	s ms $\mu\text{s}$
<b>DUTY CYCLE ADJUST</b> Duty Cycle Range Duty Cycle Accuracy vs Supply Voltage Nonlinearity <sup>(6)</sup>	50% Duty Cycle, $R_{PWM} = 28.7\text{k}\Omega$ 50% Duty Cycle, $V_S = V_O = +9\text{V}$ to +60V 10% to 80% Duty Cycle		10 to 90 $\pm 2$ $\pm 1$ 2	$\pm 5$ $\pm 5$	% % % % FSR
<b>DYNAMIC RESPONSE</b> Output Voltage Rise Time Output Voltage Fall Time Oscillator Frequency	$V_O = 10\%$ to $90\%$ of $V_S$ $V_O = 90\%$ to $10\%$ of $V_S$		1 0.1 24	2.5 2.5 29	$\mu\text{s}$ $\mu\text{s}$ kHz
<b>FLAG</b> Normal Operation Fault <sup>(7)</sup> Sink Current Under-Current Flag: Set Reset Over-Current Flag: Set Reset	$20\text{k}\Omega$ Pull-Up to +5V, $I_O < 1.5\text{A}$ Sinking $1\text{mA}$ $V_{\overline{\text{FLAG}}} = 0.4\text{V}$	+4	+4.9 +0.2 2 4 2 2 2	+0.8	V V mA $\mu\text{s}$ $\mu\text{s}$ $\mu\text{s}$ $\mu\text{s}$
<b>THERMAL SHUTDOWN</b> Junction Temperature Shutdown Reset from Shutdown				+165 +150	$^\circ\text{C}$ $^\circ\text{C}$
<b>POWER SUPPLY</b> Specified Operating Voltage Operating Voltage Range Quiescent Current	$I_O = 0$	+9	+24 3.5	+60 5	V V mA
<b>TEMPERATURE RANGE</b> Specified Range Operating Range Storage Range Thermal Resistance, $\theta_{JC}$ 7-Lead DDPAK, 7-Lead TO-220 Thermal Resistance, $\theta_{JA}$ 7-Lead DDPAK, 7-Lead TO-220	No Heat Sink	-40 -55 -65		+85 +125 +150 3 65	$^\circ\text{C}$ $^\circ\text{C}$ $^\circ\text{C}$ $^\circ\text{C}/\text{W}$ $^\circ\text{C}/\text{W}$

NOTES:(1) Under-scale current for  $T_C < 100^\circ\text{C}$ —see Under-Scale Current vs Temperature typical performance curve. (2) Logic High enables output (normal operation). (3) Constant dc output to PWM (pulse-width modulated) time. (4) Maximum delay is determined by an external capacitor. Pulling the Delay Adjust Pin low corresponds to an infinite (continuous) delay. (5) Connecting the Delay Adjust pin to +5V reduces delay time to  $3\mu\text{s}$ . (6)  $V_{IN}$  at pin 3 to percent of duty cycle at pin 6. (7) A fault results from over-temperature, over-current, or under-current conditions.

## CONNECTION DIAGRAMS

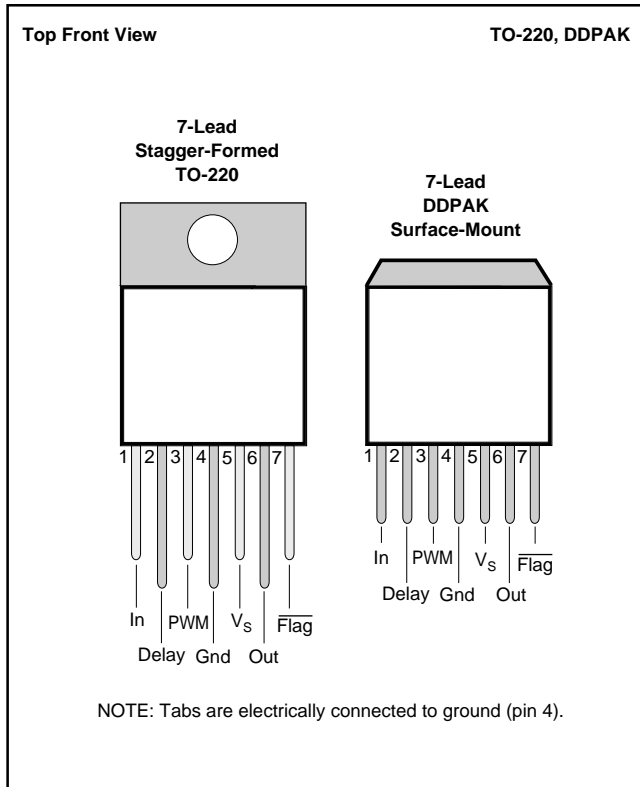

## ABSOLUTE MAXIMUM RATINGS<sup>(1)</sup>

Supply Voltage, $V_S$ .....	60V
Input Voltage .....	-0.2V to $V_S$
PWM Adjust Input .....	-0.2V to $V_S$
Delay Adjust Input .....	-0.2V to $V_S$ (24V max)
Operating Temperature Range .....	-40°C to +125°C
Storage Temperature Range .....	-65°C to +150°C
Junction Temperature .....	+150°C
Lead Temperature (soldering, 10s) <sup>(2)</sup> .....	+300°C

NOTES: (1) Stresses above these ratings may cause permanent damage. Exposure to absolute maximum conditions for extended periods may degrade device reliability. (2) Vapor-phase or IR reflow techniques are recommended for soldering the DRV101F surface-mount package. Wave soldering is not recommended due to excessive thermal shock and "shadowing" of nearby devices.



## ELECTROSTATIC DISCHARGE SENSITIVITY

This integrated circuit can be damaged by ESD. Texas Instruments recommends that all integrated circuits be handled with appropriate precautions. Failure to observe proper handling and installation procedures can cause damage.

ESD damage can range from subtle performance degradation to complete device failure. Precision integrated circuits may be more susceptible to damage because very small parametric changes could cause the device not to meet its published specifications.

## PACKAGE/ORDERING INFORMATION

For the most current package and ordering information, see the Package Ordering Addendum at the end of this data sheet.

## PIN DESCRIPTIONS

PIN #	NAME	DESCRIPTION
Pin 1	Input	The input is compatible with standard TTL levels. The device output becomes enabled when the input voltage is driven above the typical switching threshold, 1.7V. Below this level, the output is disabled. With no connection to the pin, the input level rises to 3.4V. Input current is 20 $\mu$ A when driven high and 80 $\mu$ A with the input low. The input may be momentarily driven to the power supply ( $V_S$ ) without damage.
Pin 2	Delay Adjust	This pin sets the duration of the initial 100% duty cycle before the output goes into PWM mode. Leaving this pin floating results in a delay of approximately 15 $\mu$ s, which is internally limited by parasitic capacitance. Minimum delay may be reduced to less than 3 $\mu$ s by tying the pin to 5V. This pin connects internally to a 3 $\mu$ A current source from $V_S$ and to a 3V threshold comparator. When the pin voltage is below 3V, the output device is 100% on. The PWM oscillator is not synchronized to the Input (pin 1), so the first pulse may be extended by any portion of the programmed duty cycle.
Pin 3	Duty Cycle Adjust (PWM)	Internally, this pin connects to the input of a comparator and a 19k $\Omega$ resistor to ground. It is driven by a 200 $\mu$ A current source from $V_S$ . The voltage at this node linearly sets the duty cycle. Duty cycle can be programmed with a resistor, analog voltage, or output of a D/A converter. The active voltage range is from 0.75V to 3.7V to facilitate the use of single-supply control electronics. At 0.75V (or $R_{PWM} = 3.5k\Omega$ ), duty cycle is near 90%. Swing to ground should be limited to no lower than 0.1V. PWM frequency is a constant 24kHz.
Pin 4	Ground	This pin is electrically connected to the package tab. It must be connected to system ground for the DRV101 to function. It carries the 3.5mA quiescent current plus the load current when the device is on.
Pin 5	$V_S$	This is the power supply pin. Operating range is +9V to +60V.
Pin 6	Out	The output is the collector of a power npn with the emitter connected to ground. Low power dissipation in the DRV101 is attained by the low saturation voltage and the fast switching transitions. Fall time is less than 75ns, rise time depends on load impedance. Base drive to the power device is limited with light loads to control turn-off delay. The response of this circuit causes the brief dip in saturation voltage after turn on. A flyback diode is needed with inductive loads to conduct the load current during the off cycle. The external diode should be selected for low forward voltage. The internal clamp diode provides protection but should not be used to conduct load currents greater than 0.5A.
Pin 7	Flag	Normally high (active low), the Flag signals either an over-temperature, over-current, or under-current fault. The over/under-current flags are true only when the output is on (constant dc output or the "on" portion of PWM mode). A thermal fault (thermal shutdown) occurs when the die surface reaches approximately 165 $^{\circ}$ C and latches until the die cools to 150 $^{\circ}$ C. Its output requires a pull-up resistor. It can typically sink two milliamps, sufficient to drive a low-current LED.

## LOGIC BLOCK DIAGRAM

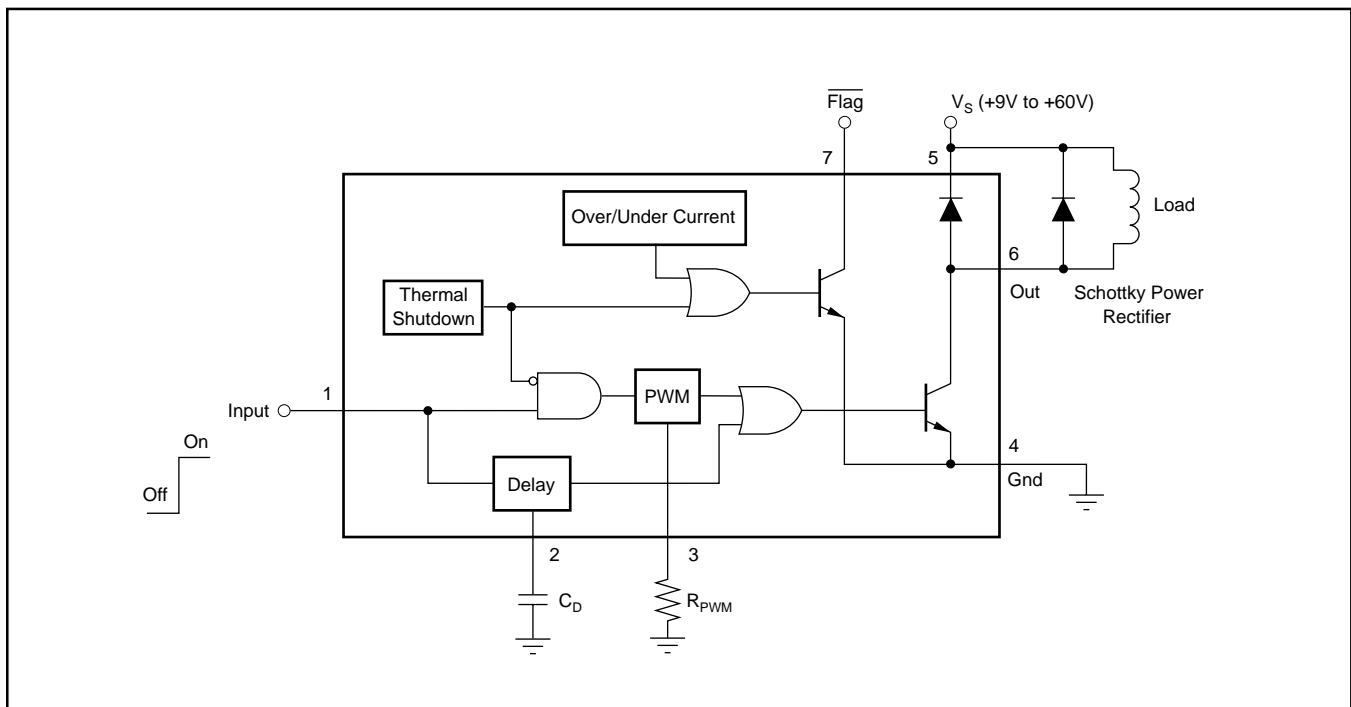

# TYPICAL PERFORMANCE CURVES

At  $T_C = +25^\circ\text{C}$  and  $V_S = +24\text{V}$ , unless otherwise noted.

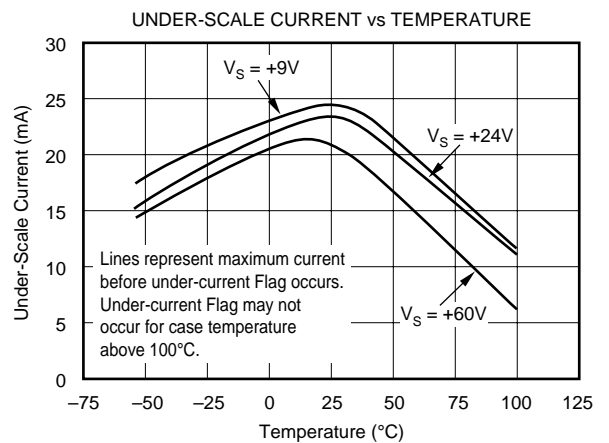
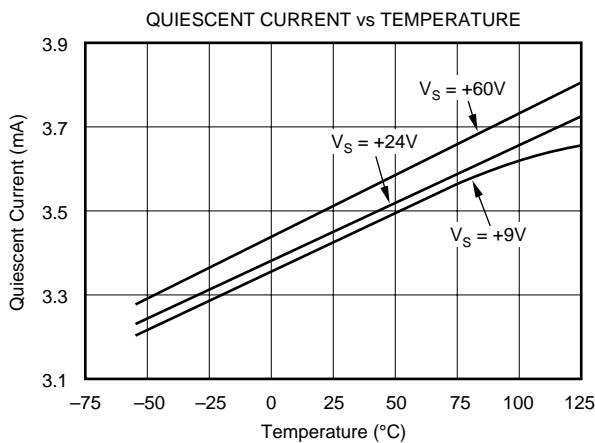
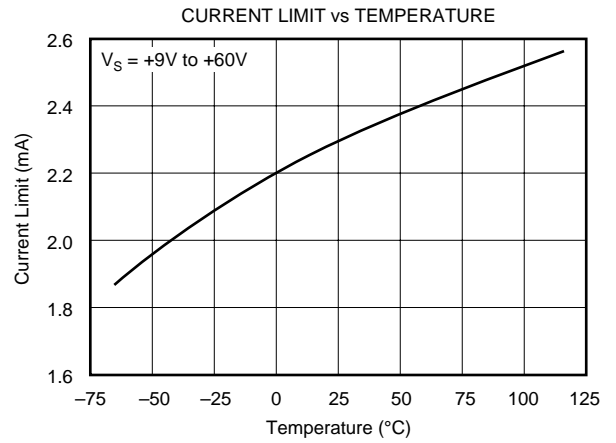
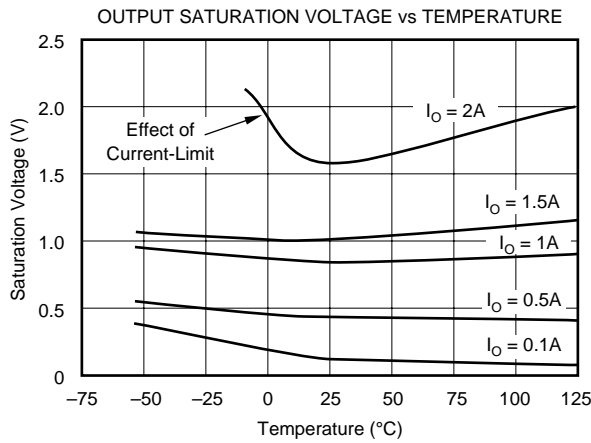
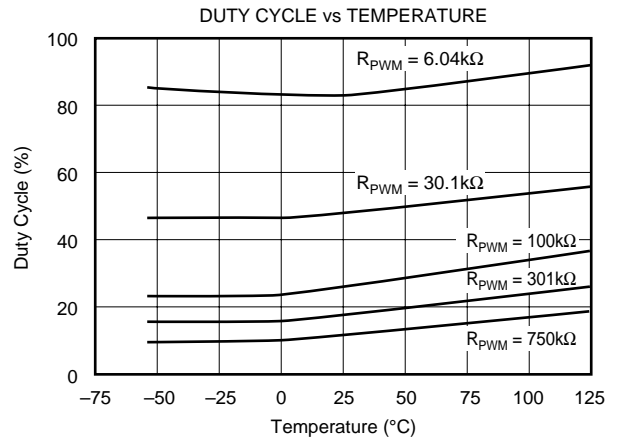
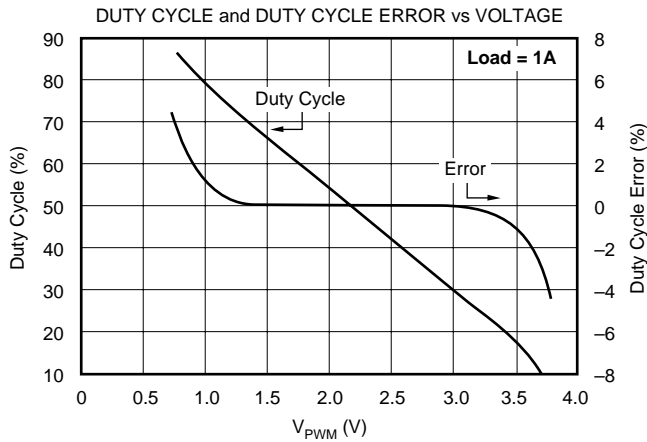

# TYPICAL PERFORMANCE CURVES (CONT)

At  $T_C = +25^\circ\text{C}$  and  $V_S = +24\text{V}$ , unless otherwise noted.

FLAG OPERATION  
OVER-CURRENT LIMIT  
( $V_S = +60\text{V}$ ,  $C_D = 110\text{pF}$ ,  $R_{\text{PWM}} = 750\text{k}\Omega$ )

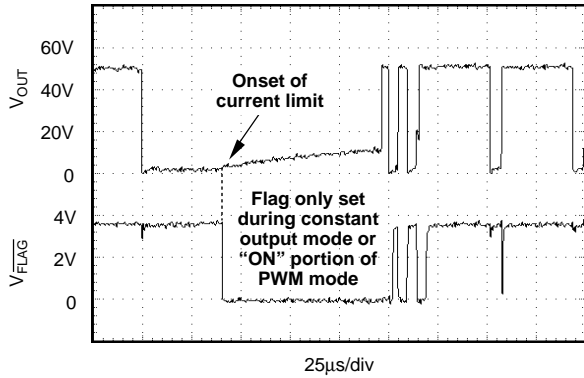

FLAG OPERATION  
UNDER-CURRENT  
( $V_S = +24\text{V}$ ,  $C_D = 110\text{pF}$ ,  $R_{\text{PWM}} = 6.04\text{k}\Omega$ )

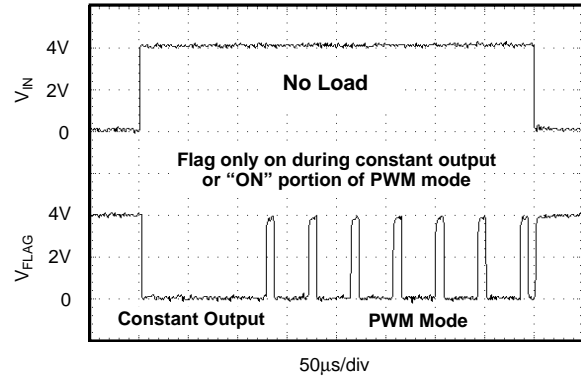

DC TO PWM MODE  
DRIVING INDUCTIVE LOAD  
( $V_S = +60\text{V}$ ,  $C_D = 110\text{pF}$ ,  $R_{\text{PWM}} = 301\text{k}\Omega$ )

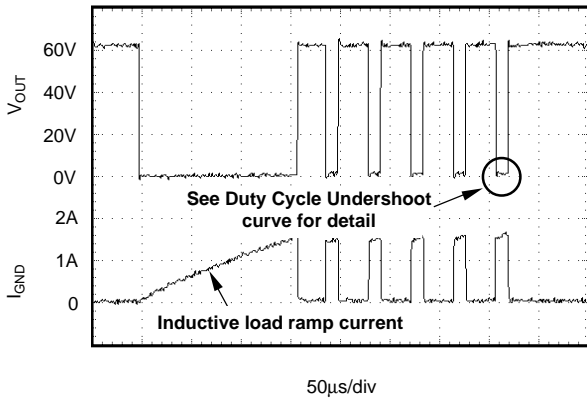

DUTY CYCLE UNDERSHOOT  
Load = 1A

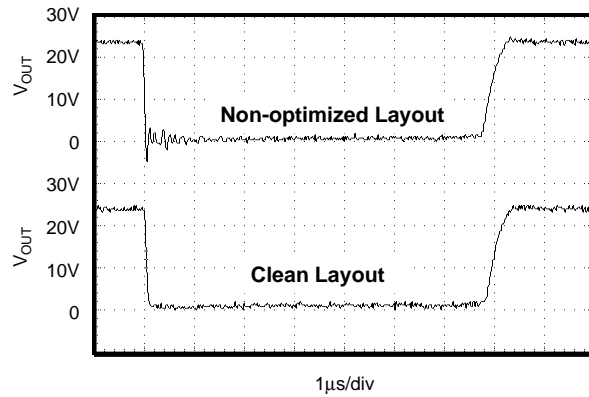

TYPICAL SOLENOID CURRENT WAVEFORM  
( $V_S = +24\text{V}$ )

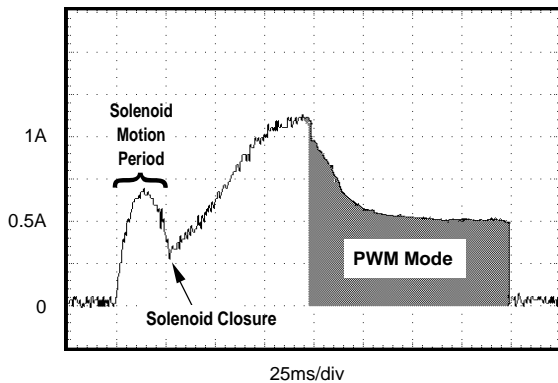

OSCILLATOR FREQUENCY vs TEMPERATURE

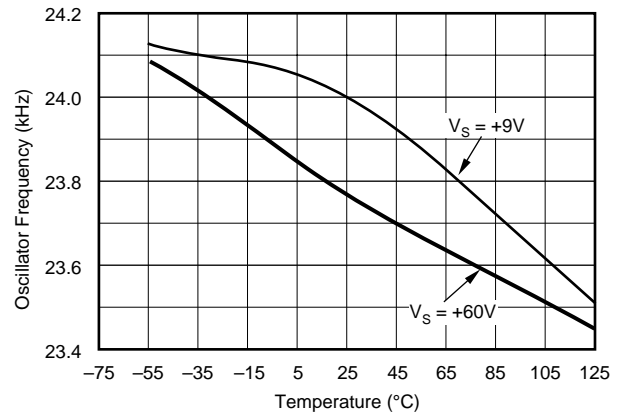

# TYPICAL PERFORMANCE CURVES (CONT)

At  $T_C = +25^\circ\text{C}$  and  $V_S = +24\text{V}$ , unless otherwise noted.

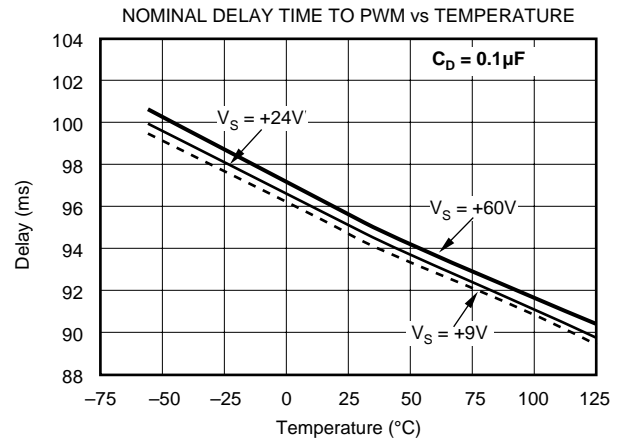
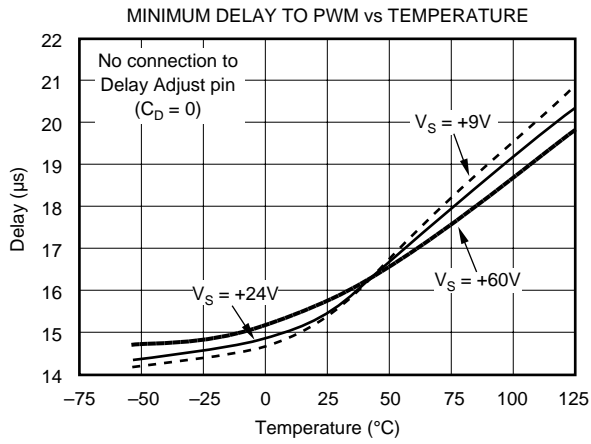

# BASIC OPERATION

The DRV101 is a low-side, bipolar power switch employing a pulse-width modulated (PWM) output for driving electro-mechanical and thermal devices. Its design is optimized for two types of applications; a two-state driver (open/close) for loads such as solenoids and actuators, and a linear driver for valves, positioners, heaters, and lamps. Its wide supply range, adjustable delay to PWM mode, and adjustable duty cycle make it suitable for a wide range of applications. Figure 1 shows the basic circuit connections to operate the DRV101. A 0.1µF bypass capacitor is shown connected to the power supply pin.

The Input (pin 1) is compatible with standard TTL levels. Input voltages between +2.2V and +5.5V turn the device output on, while pulling the pin low (0V to +1.2V), shuts the DRV101 output off. Input current is typically 80µA.

Delay Adjust (pin 2) and Duty Cycle Adjust (pin 3) allow external adjustment of the PWM output signal. The Delay Adjust pin can be left floating for minimum delay to PWM mode (typically 15µs) or a capacitor can be used to set the delay time. Duty cycle of the PWM output can be controlled

by a resistor, analog voltage, or D/A converter. Figure 1b provides an example timing diagram with the Delay Adjust pin connected to 0.1µF and duty cycle set for 25%. See the “Delay Adjust” and “Duty Cycle Adjust” text for equations and further explanation.

Ground (pin 4) is electrically connected to the package tab. This pin must be connected to system ground for the DRV101 to function. This serves as the load current path to ground, as well as the DRV101 reference ground.

The load (solenoid, valve, etc.) is connected between the supply (pin 5) and output (pin 6). For an inductive load, an external diode across the output is required as shown in Figure 1a. The diode serves to maintain the hold force during PWM operation. For remotely located loads, the external diode should be placed close to the DRV101 (Figure 1a). The internal clamp diode between the output and ground should not be used to carry load current.

The  $\overline{\text{Flag}}$  (pin 7) provides fault status for under-current, over-current, and thermal shutdown conditions. This pin is active low with pin voltage typically +0.3V during a fault condition. A small value capacitor may be needed between  $\overline{\text{Flag}}$  and ground for noisy applications.

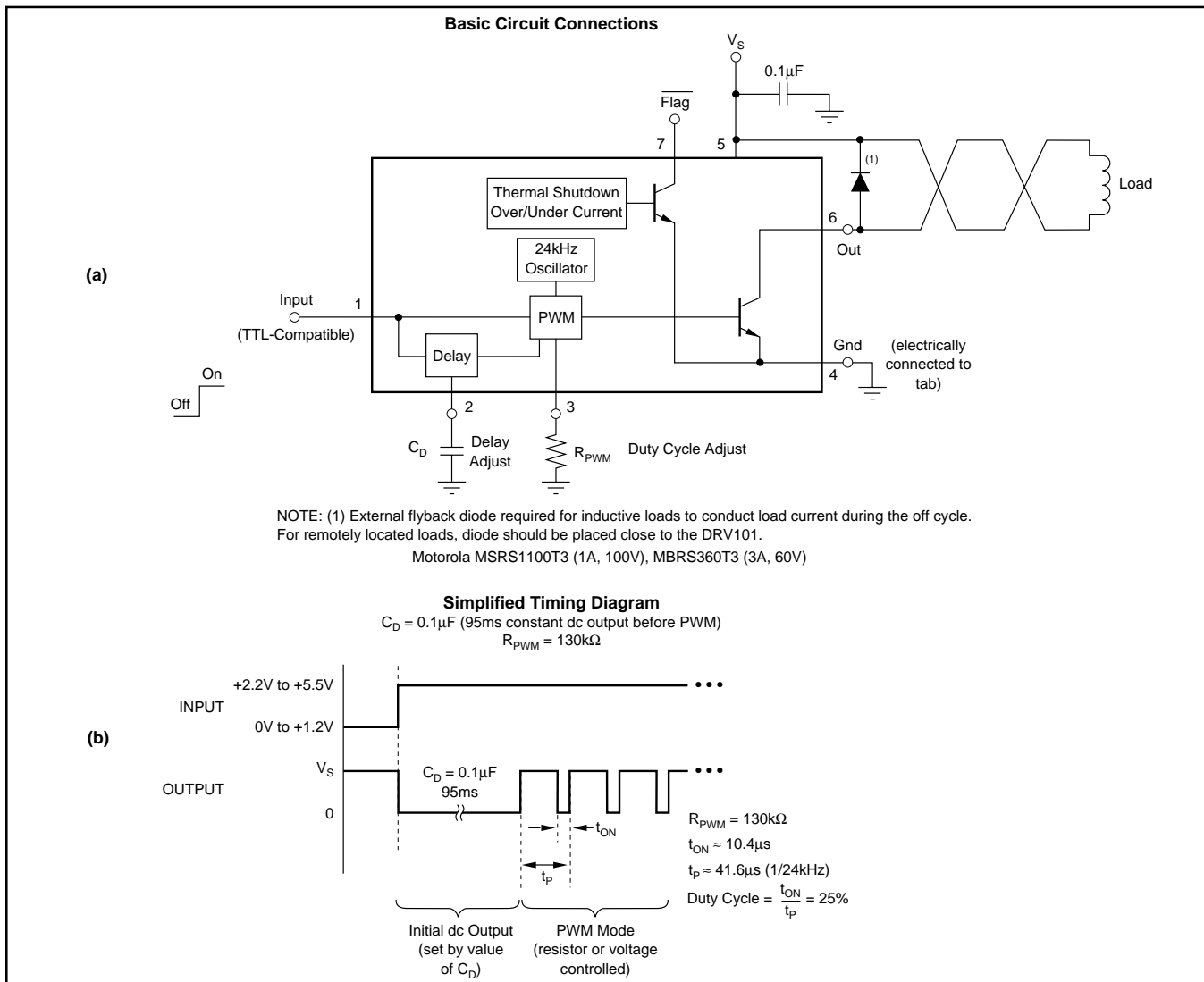

FIGURE 1. Basic Circuit Connections and Timing Diagram.



# APPLICATIONS INFORMATION

## POWER SUPPLY

The DRV101 operates from a single +9V to +60V supply with excellent performance. Most behavior remains unchanged throughout the full operating voltage range. Parameters which vary significantly with operating voltage are shown in the Typical Performance Curves.

## ADJUSTABLE INITIAL 100% DUTY CYCLE

A unique feature of the DRV101 is its ability to provide an initial constant dc output (100% duty cycle) and then switch to PWM mode to save power. This function is particularly useful when driving solenoids which have a much higher pull-in current requirement than hold requirement.

The duration of this constant dc output (before PWM output begins) can be externally controlled with a capacitor connected from Delay Adjust (pin 2) to ground according to the following equation:

$$\text{Delay Time} \approx C_D \cdot 10^6$$

(time in seconds,  $C_D$  in Farads)

Leaving the Delay Adjust pin open results in a constant output time of approximately 15 $\mu$ s. The duration of this initial output can be reduced to less than 3 $\mu$ s by connecting the pin to 5V. Table I provides examples of desired “delay” times (constant output before PWM mode) and the appropriate capacitor values or pin connection.

CONSTANT OUTPUT DURATION	$C_D$
3 $\mu$ s	Pin connected to 5V
15 $\mu$ s	Pin open
100 $\mu$ s	100pF
1ms	1nF
100ms	0.1 $\mu$ F

TABLE I. Delay Adjust Pin Connections.

The internal Delay Adjust circuitry is composed of a 3 $\mu$ A current source and a 3V comparator as shown in Figure 2. Thus, when the pin voltage is less than 3V, the output device is 100% on (dc output mode).

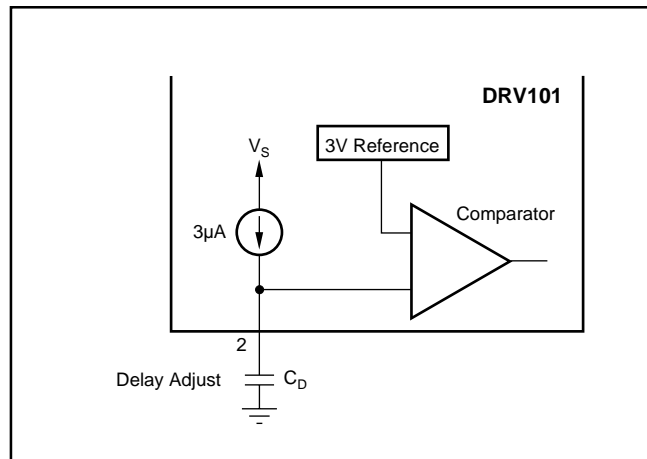

FIGURE 2. Simplified Circuit Model of the Delay Adjust Pin.

## ADJUSTABLE DUTY CYCLE

The DRV101’s externally adjustable duty cycle provides an accurate means of controlling power delivered to the load. Duty cycle can be set from 10% to 100% with an external resistor, analog voltage, or the output of a D/A converter. Reduced duty cycle results in reduced power dissipation. This keeps the DRV101 and load cooler, resulting in increased reliability for both devices. PWM frequency is a constant 24kHz.

## Resistor Controlled Duty Cycle

Duty cycle is easily programmed with a resistor ( $R_{PWM}$ ) connected between the Duty Cycle Adjust pin and ground. Increased resistor values correspond to decreased duty cycles. Table II provides resistor values for typical duty cycles. Resistor values for additional duty cycles can be obtained from Figure 3. For reference purposes, the equation for calculating  $R_{PWM}$  is included in Figure 3.

DUTY CYCLE	RESISTOR <sup>(1)</sup> $R_{PWM}$ (k $\Omega$ )	VOLTAGE <sup>(2)</sup> $V_{PWM}$ (V)
10	976	3.7
20	205	3.4
30	84.5	3.0
40	46.4	2.6
50	28.7	2.2
60	18.2	1.75
70	11.8	1.35
80	7.50	1.00
90	4.87	0.75

NOTES: (1) Resistor values listed are nearest 1% standard values. (2) Do not drive pin below 0.1V. For additional values, see “Duty Cycle vs Voltage” typical performance curve.

TABLE II. Duty Cycle Adjust.  $T_A = +25^\circ\text{C}$ ,  $V_S = +24\text{V}$ .

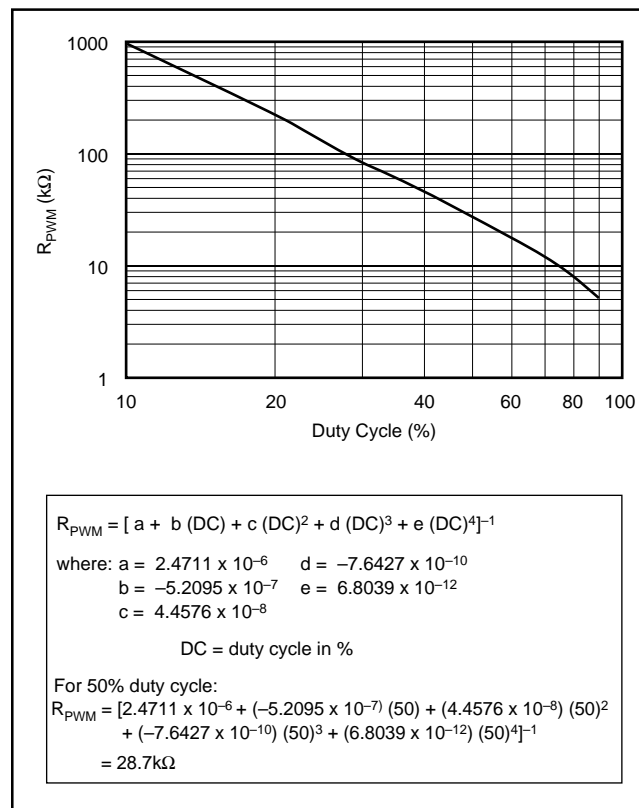

FIGURE 3.  $R_{PWM}$  vs Duty Cycle.

## Voltage Controlled Duty Cycle

Duty cycle can also be programmed with an analog voltage,  $V_{PWM}$ . With  $V_{PWM} \approx 0.75V$ , duty cycle is near 90%. Increasing this voltage results in decreased duty cycles. Table II provides  $V_{PWM}$  values for typical duty cycles. See the “Duty Cycle vs Voltage” Typical Performance Curve for additional duty cycles.

The Duty Cycle Adjust pin should not be driven below 0.1V. If the voltage source used can go between 0.1V and ground, a series resistor between the voltage source and the Duty Cycle Adjust pin (Figure 4) is required to limit swing. If the pin is driven below 0.1V, the output will be unpredictable.

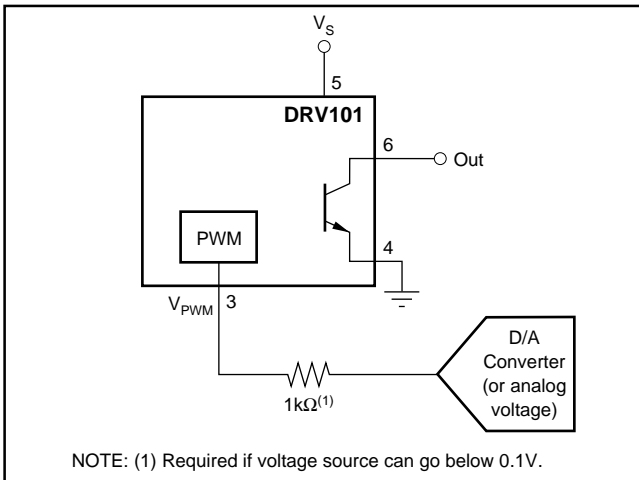

FIGURE 4. Using a Voltage to Program Duty Cycle.

The DRV101’s internal 24kHz oscillator sets the PWM period. This frequency is not externally adjustable. Duty Cycle Adjust (pin 3) is internally driven by a 200μA current source and connects to the input of a comparator and a 19kΩ resistor as shown in Figure 5. The DRV101’s PWM control design is inherently monotonic. That is, a decreased voltage (or resistor value) always produces an increased duty cycle.

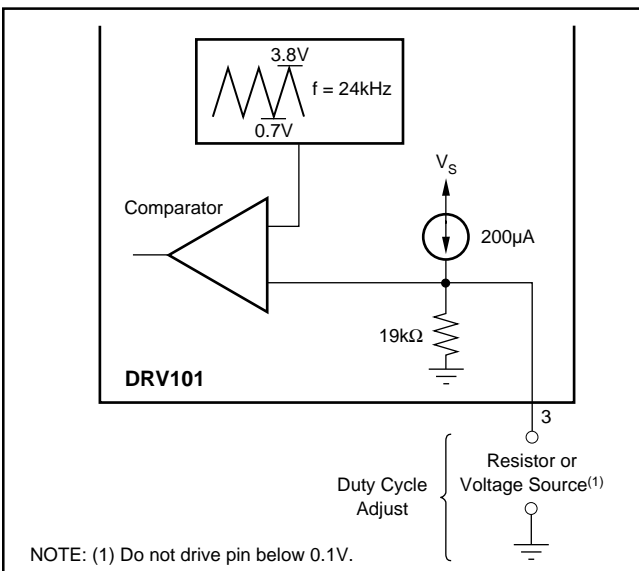

FIGURE 5. Simplified Circuit Model of the Duty Cycle Adjust Pin.

## STATUS FLAG

$\overline{\text{Flag}}$  (pin 7) provides fault indication for under-current, over-current, and thermal shutdown conditions. During a fault condition,  $\overline{\text{Flag}}$  output is driven low (pin voltage typically drops to 0.3V). A pull-up resistor, as shown in Figure 6, is required to interface with standard logic. A small value capacitor may be needed between  $\overline{\text{Flag}}$  and ground in noisy applications.

Figure 6 gives an example of a non-latching fault monitoring circuit, while Figure 7 provides a latching version. The  $\overline{\text{Flag}}$  pin can sink several milliamps, sufficient to drive external logic circuitry or an LED (Figure 8) to indicate when a fault has occurred. In addition, the Flag pin can be used to turn off other DRV101’s in a system for chain fault protection.

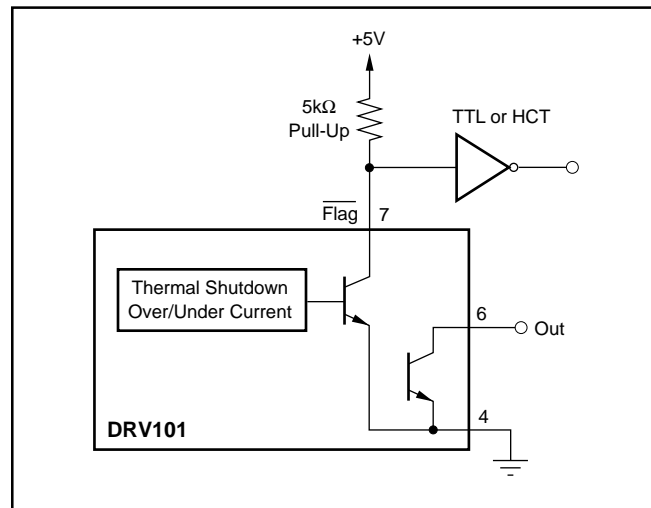

FIGURE 6. Non-Latching Fault Monitoring Circuit.

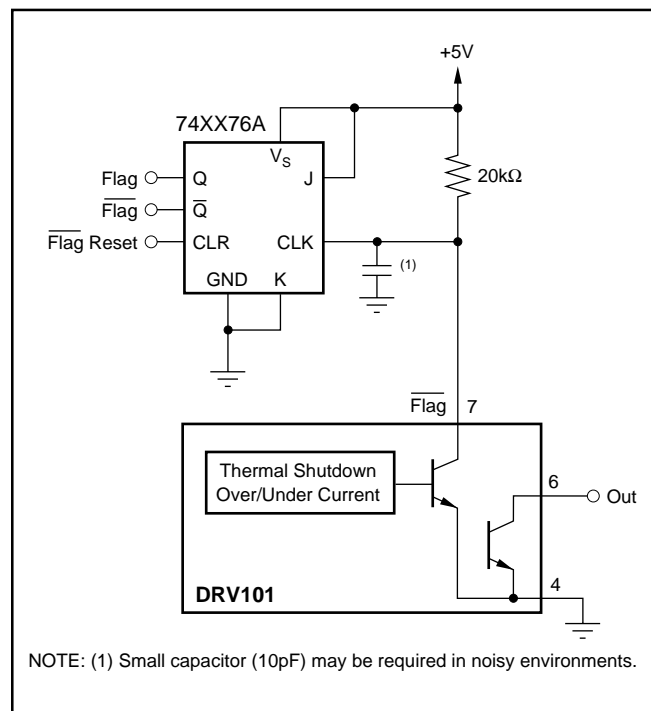

FIGURE 7. Latching Fault Monitoring Circuit.

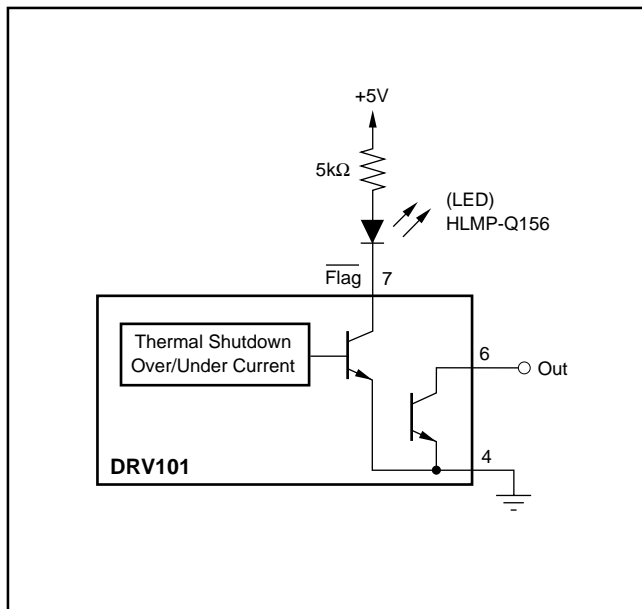

FIGURE 8. LED to Indicate Fault Condition.

### Over/Under Current Fault

An over-current fault occurs when the output current is greater than approximately 2.3A. The status flag is not latched. Since current during PWM mode is switched on and off, the flag output will be modulated with PWM timing (see flag waveforms in the Typical Performance Curves).

An under-current fault occurs when the output current is below the under-scale current threshold (typically 23mA). For example, this function indicates when the load is disconnected. Again, the flag output is not latched, so an under-current condition during PWM mode will produce a flag output that is modulated by the PWM waveform. An initial, brief under-current flag normally appears driving inductive loads and may be avoided by adding a parallel resistor sufficient to move the initial current above the under-current threshold. An under-current flag may not appear for case temperatures above 100°C. Avoid adding capacitance to pin 6 (Out) as it may cause momentary current limiting.

### Over-Temperature Fault

A thermal fault occurs when the die reaches approximately 165°C, producing a similar effect as pulling the input low. Internal shutdown circuitry disables the output and resets the Delay Adjust pin. The  $\overline{\text{Flag}}$  is latched in the low state (fault condition) until the die has cooled to approximately 150°C. A thermal fault can occur in any mode of operation. Recovery from thermal fault will start in delay mode (constant dc output).

### PACKAGE MOUNTING

Figure 9 provides recommended PCB layouts for both the TO-220 and DDPAK power packages. The tab of both packages is electrically connected to ground (pin 4). It may be desirable to isolate the tab of TO-220 package from its mounting surface with a mica (or other film) insulator (see

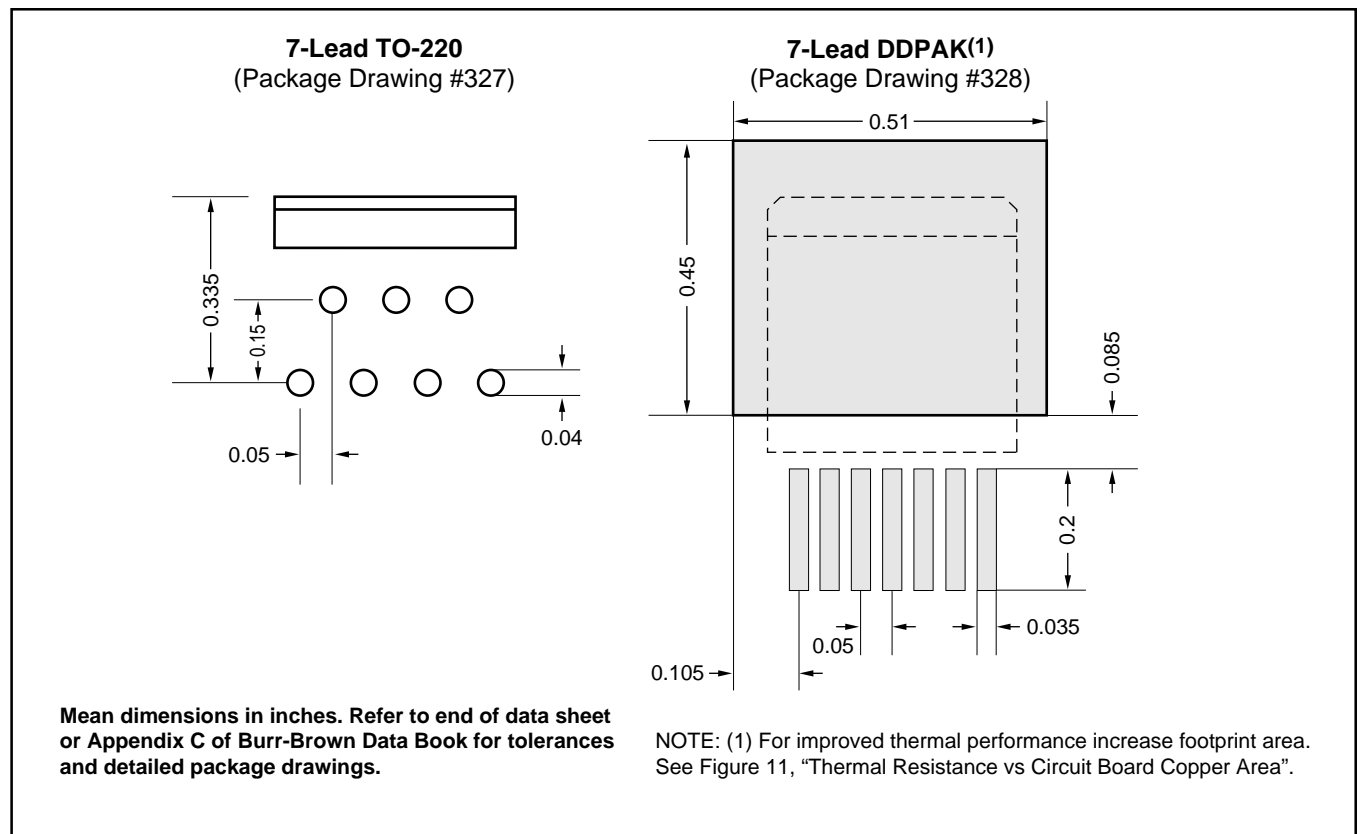

FIGURE 9. TO-220 and DDPAK Solder Footprints.

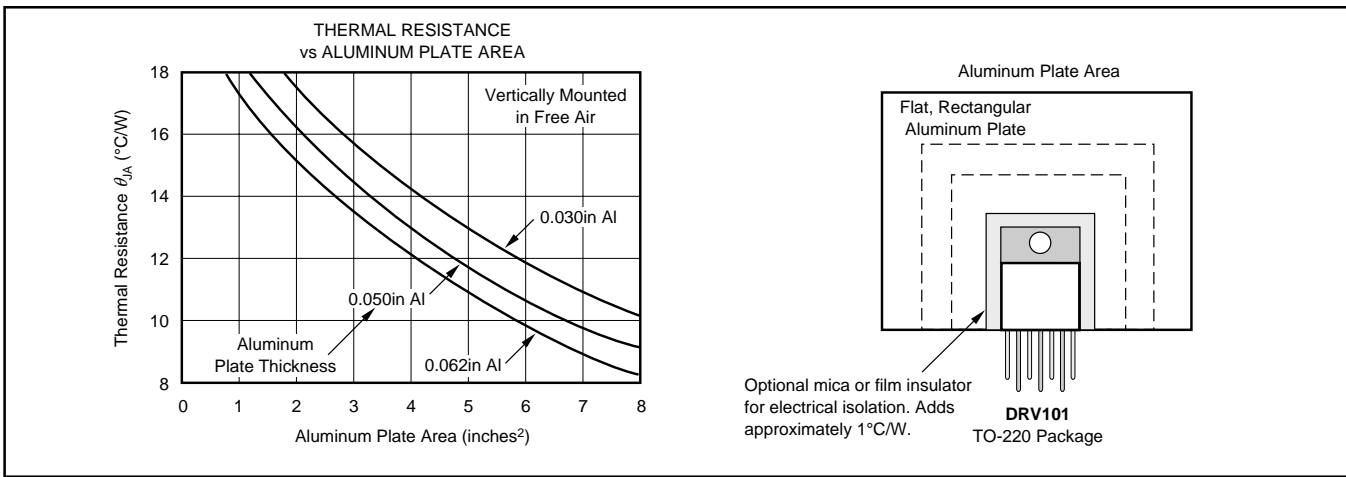

FIGURE 10. TO-220 Thermal Resistance vs Aluminum Plate Area.

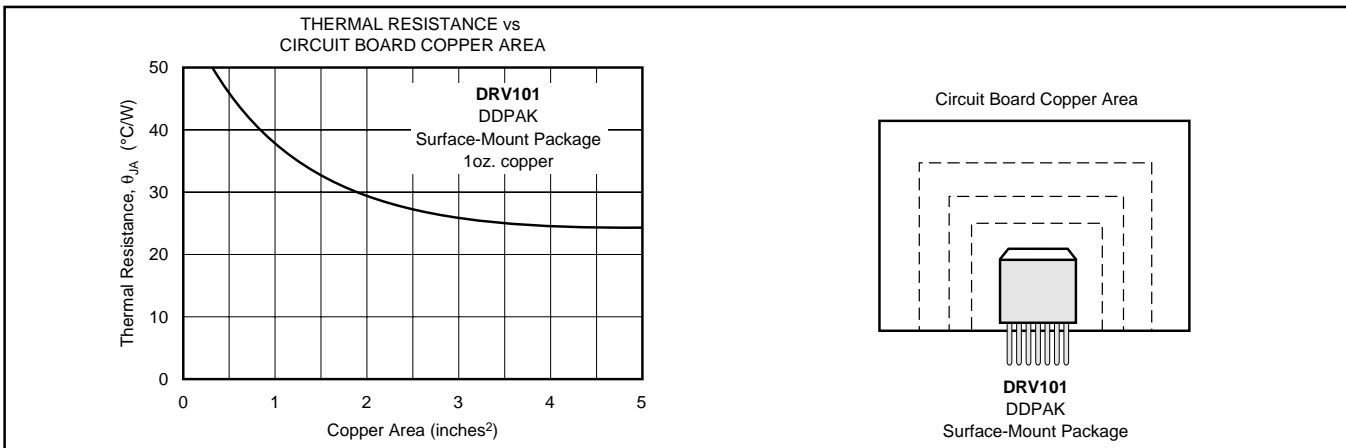

FIGURE 11. DDPAK Thermal Resistance vs Circuit Board Copper Area.

Figure 10). For lowest overall thermal resistance, it is best to isolate the entire heat sink/DRV101 structure from the mounting surface rather than to use an insulator between the semiconductor and heat sink.

For best thermal performance, the tab of the DDPAK surface-mount version should be soldered directly to a circuit board copper area. Increasing the copper area improves heat dissipation. Figure 11 shows typical thermal resistance from junction-to-ambient as a function of the copper area.

## POWER DISSIPATION

Power dissipation depends on power supply, signal, and load conditions. Power dissipation is equal to the product of output current times the voltage across the conducting output transistor times the duty cycle. Power dissipation can be minimized by using the lowest possible duty cycle necessary to assure the required hold force.

Application Bulletin AB-039 explains how to calculate or measure power dissipation with unusual signals and loads.

## THERMAL PROTECTION

Power dissipated in the DRV101 will cause the junction temperature to rise. The DRV101 has thermal shutdown circuitry that protects the device from damage. The thermal

protection circuitry disables the output when the junction temperature reaches approximately +165°C, allowing the device to cool. When the junction temperature cools to approximately +150°C, the output circuitry is again enabled. Depending on load and signal conditions, the thermal protection circuit may cycle on and off. This limits the dissipation of the amplifier but may have an undesirable effect on the load.

Any tendency to activate the thermal protection circuit indicates excessive power dissipation or an inadequate heat sink. For reliable operation, junction temperature should be limited to +125°C, maximum. To estimate the margin of safety in a complete design (including heat sink), increase the ambient temperature until the thermal protection is triggered. Use worst-case load and signal conditions. For good reliability, thermal protection should trigger more than 40°C above the maximum expected ambient condition of your application. This produces a junction temperature of 125°C at the maximum expected ambient condition.

The internal protection circuitry of the DRV101 was designed to protect against overload conditions. It was not intended to replace proper heat sinking. Continuously running the DRV101 into thermal shutdown will degrade reliability.

## HEAT SINKING

Most applications will not require a heat sink to assure that the maximum operating junction temperature (125°C) is not exceeded. However, junction temperature should be kept as low as possible for increased reliability. Junction temperature can be determined according to the equation:

$$T_J = T_A + P_D \theta_{JA} \quad (1)$$

$$\text{where, } \theta_{JA} = \theta_{JC} + \theta_{CH} + \theta_{HA} \quad (2)$$

$T_J$  = Junction Temperature (°C)

$T_A$  = Ambient Temperature (°C)

$P_D$  = Power Dissipated (W)

$\theta_{JC}$  = Junction-to-Case Thermal Resistance (°C/W)

$\theta_{CH}$  = Case-to-Heat Sink Thermal Resistance (°C/W)

$\theta_{HA}$  = Heat Sink-to-Ambient Thermal Resistance (°C/W)

$\theta_{JA}$  = Junction-to-Air Thermal Resistance (°C/W)

Figure 12 shows maximum power dissipation versus ambient temperature with and without the use of a heat sink. Using a heat sink significantly increases the maximum power dissipation at a given ambient temperature as shown.

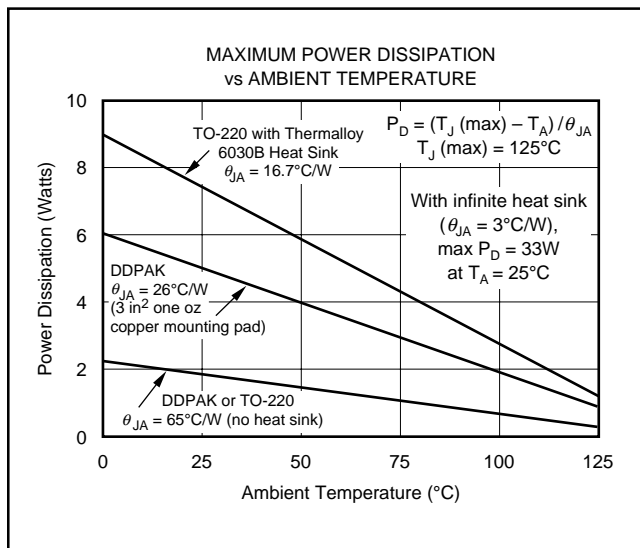

FIGURE 12. Maximum Power Dissipation vs Ambient Temperature.

The difficulty in selecting the heat sink required lies in determining the power dissipated by the DRV101. For dc output into a purely resistive load, power dissipation is simply the load current times the voltage developed across the conducting output transistor times the duty cycle. Other loads are not as simple. Consult Application Bulletin AB-039 for further insight on calculating power dissipation. Once power dissipation for an application is known, the proper heat sink can be selected.

## Heat Sink Selection Example

A TO-220 package is dissipating 5 Watts. The maximum expected ambient temperature is 35°C. Find the proper heat sink to keep the junction temperature below 125°C.

Combining Equations 1 and 2 gives:

$$T_J = T_A + P_D(\theta_{JC} + \theta_{CH} + \theta_{HA}) \quad (3)$$

$T_J$ ,  $T_A$ , and  $P_D$  are given.  $\theta_{JC}$  is provided in the specification table, 3°C/W.  $\theta_{CH}$  can be obtained from the heat sink manufacturer. Its value depends on heat sink size, area, and material used. Semiconductor package type, mounting screw torque, insulating material used (if any), and thermal joint compound used (if any) also affect  $\theta_{CH}$ . A typical  $\theta_{CH}$  for a TO-220 mounted package is 1°C/W. Now we can solve for  $\theta_{HA}$ :

$$\theta_{HA} = \frac{T_J - T_A}{P_D} - (\theta_{JC} + \theta_{CH}) \quad (4)$$

$$\theta_{HA} = \frac{125^\circ\text{C} - 35^\circ\text{C}}{5\text{W}} - (3^\circ\text{C/W} + 1^\circ\text{C/W}) = 14^\circ\text{C/W}$$

To maintain junction temperature below 125°C, the heat sink selected must have a  $\theta_{HA}$  less than 14°C/W. In other words, the heat sink temperature rise above ambient must be less than 70°C (14°C/W x 5W). For example, at 5 Watts Thermalloy model number 6030B has a heat sink temperature rise of 66°C above ambient ( $\theta_{HA} = 66^\circ\text{C}/5\text{W} = 13.2^\circ\text{C/W}$ ), which is below the 70°C required in this example. Figure 12 shows power dissipation versus ambient temperature for a TO-220 package with a 6030B heat sink.

Another variable to consider is natural convection versus forced convection air flow. Forced-air cooling by a small fan can lower  $\theta_{CA}$  ( $\theta_{CH} + \theta_{HA}$ ) dramatically. Heat sink manufacturers provide thermal data for both of these cases. For additional information on determining heat sink requirements, consult Application Bulletin AB-038.

As mentioned earlier, once a heat sink has been selected, the complete design should be tested under worst-case load and signal conditions to ensure proper thermal protection.

# APPLICATION CIRCUITS

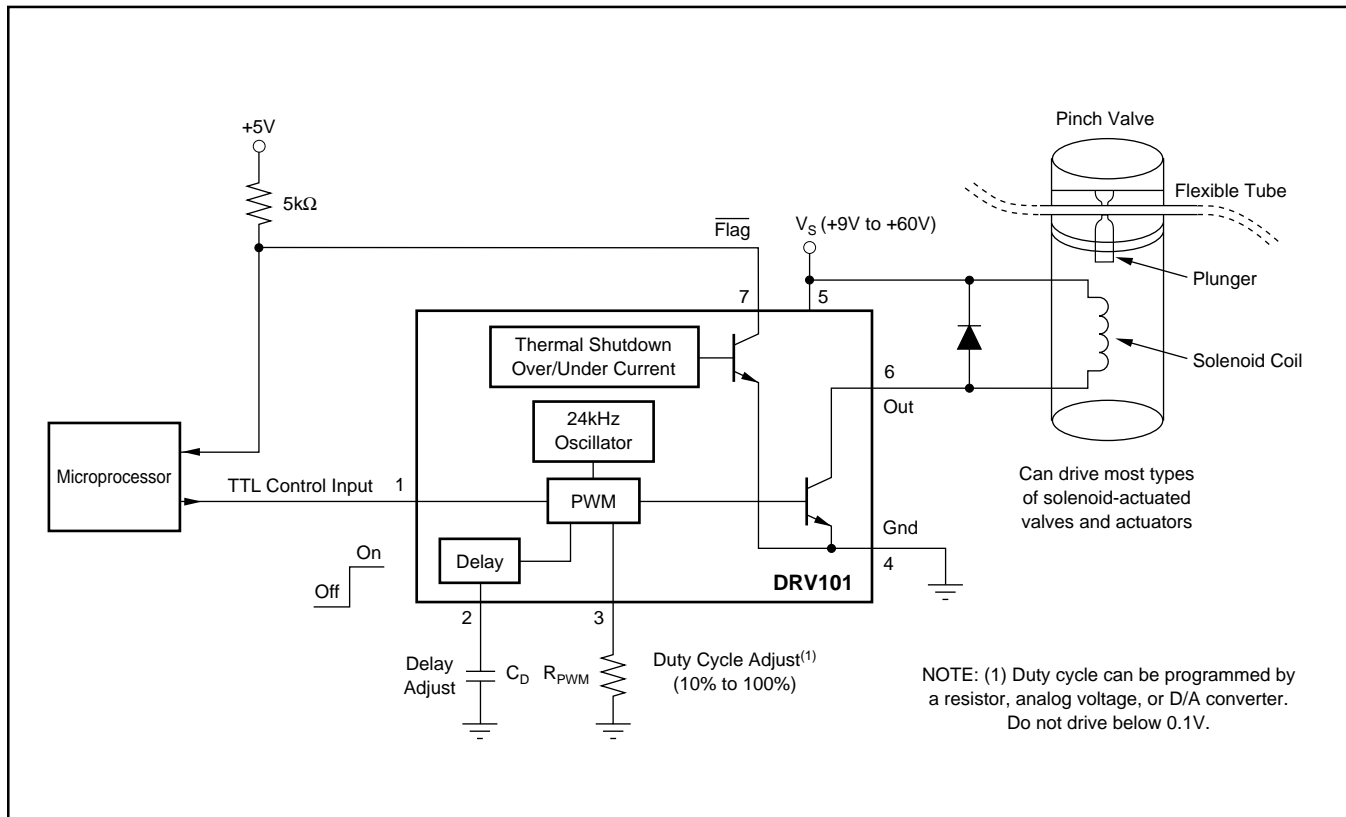

FIGURE 13. Fluid Flow Control System.

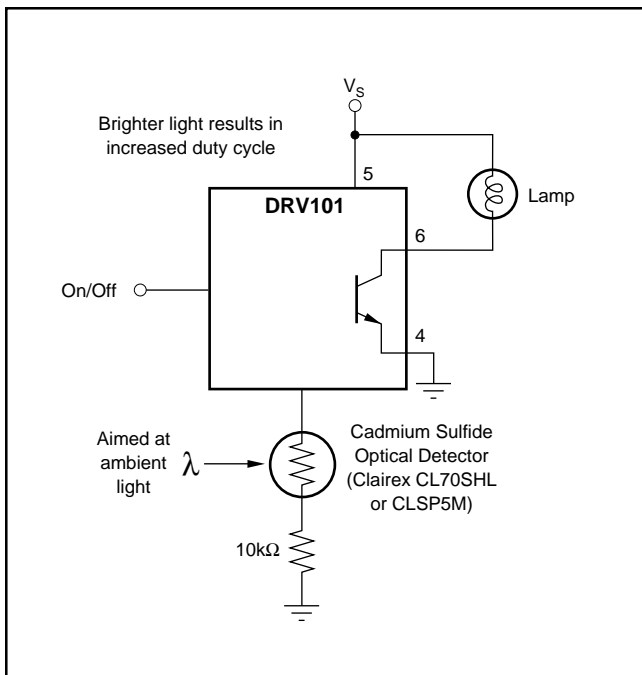

FIGURE 14. Instrument Light Dimmer Circuit.

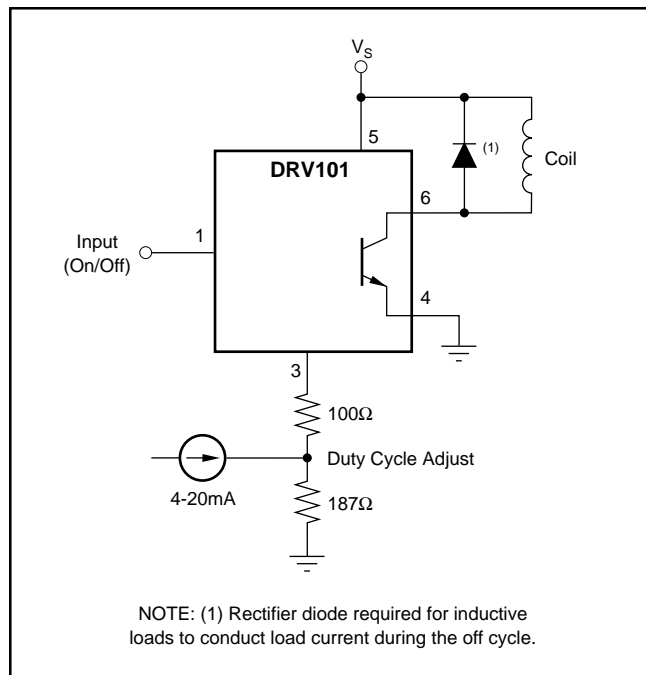

FIGURE 15. 4-20mA Input to PWM Output.

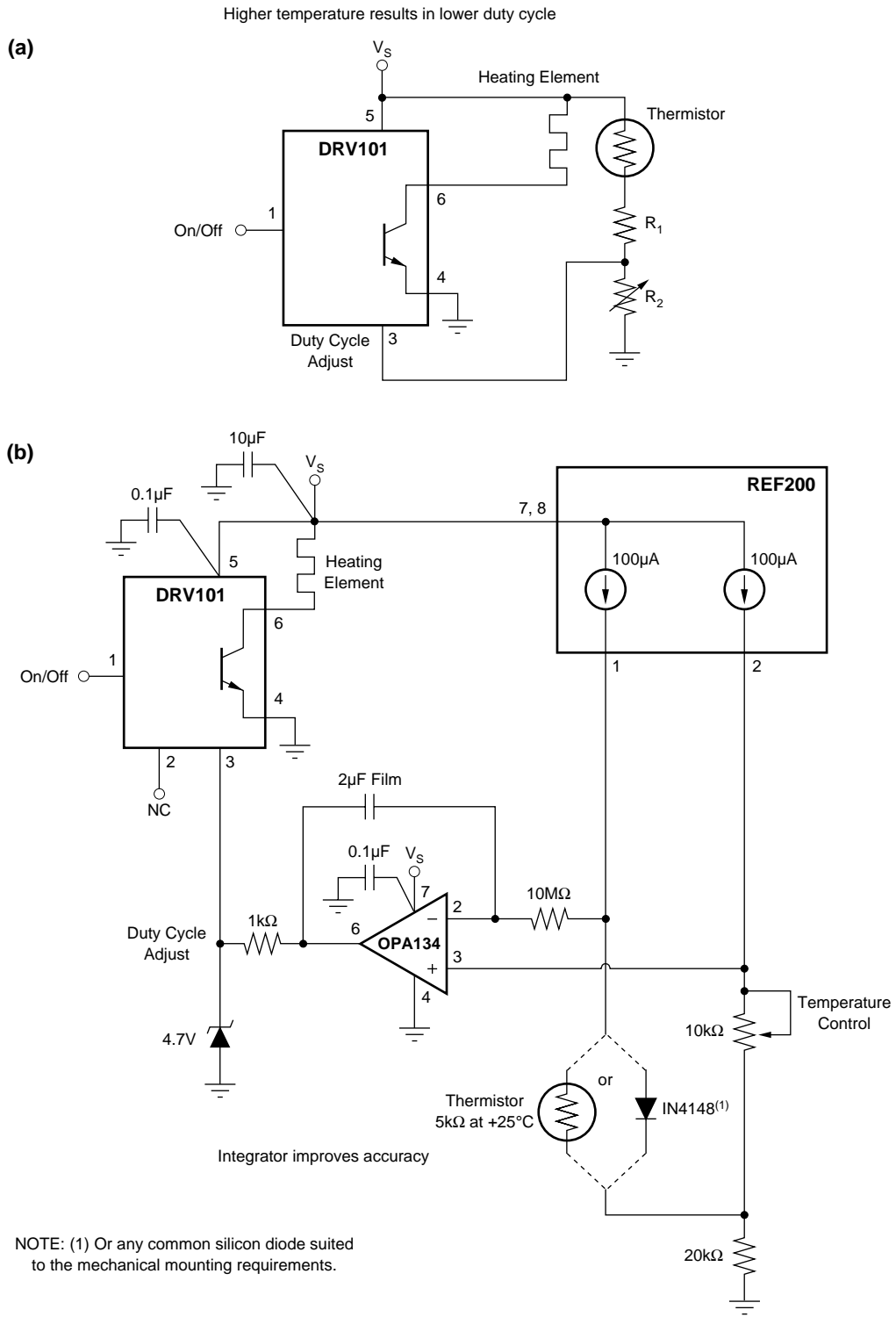

FIGURE 16. Temperature Controller.

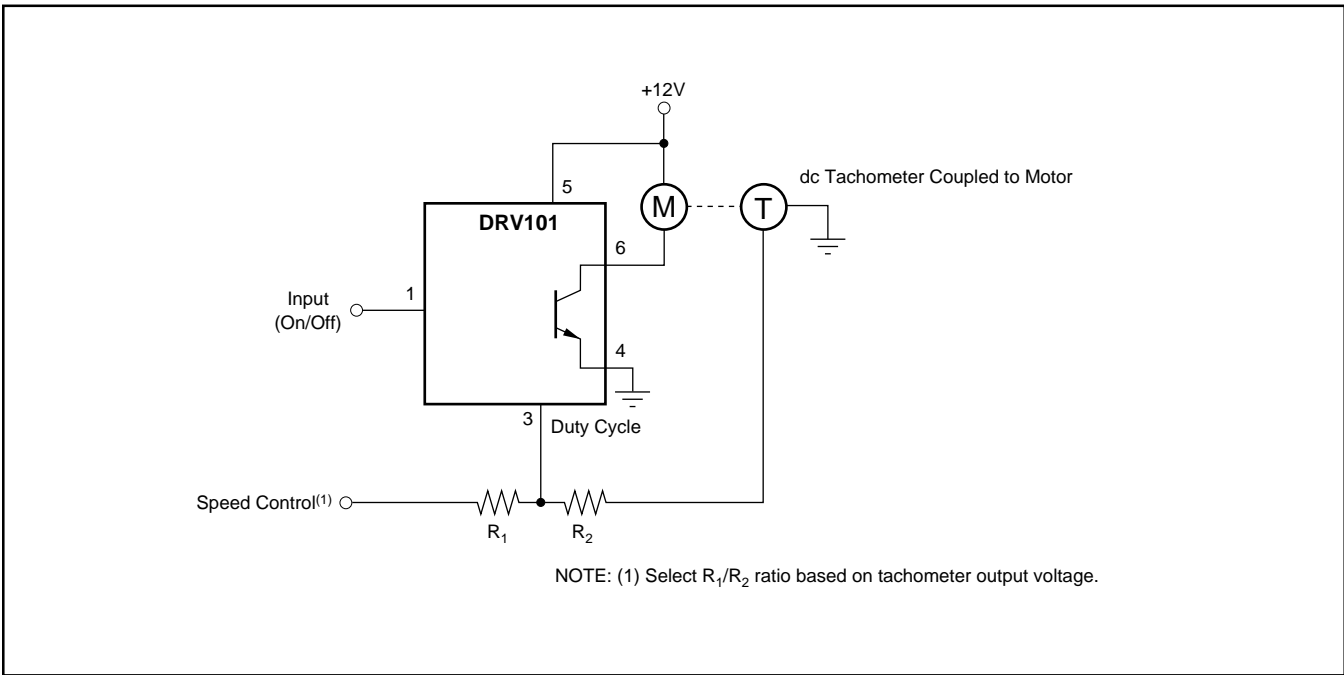

FIGURE 17. Constant Speed Motor Control.

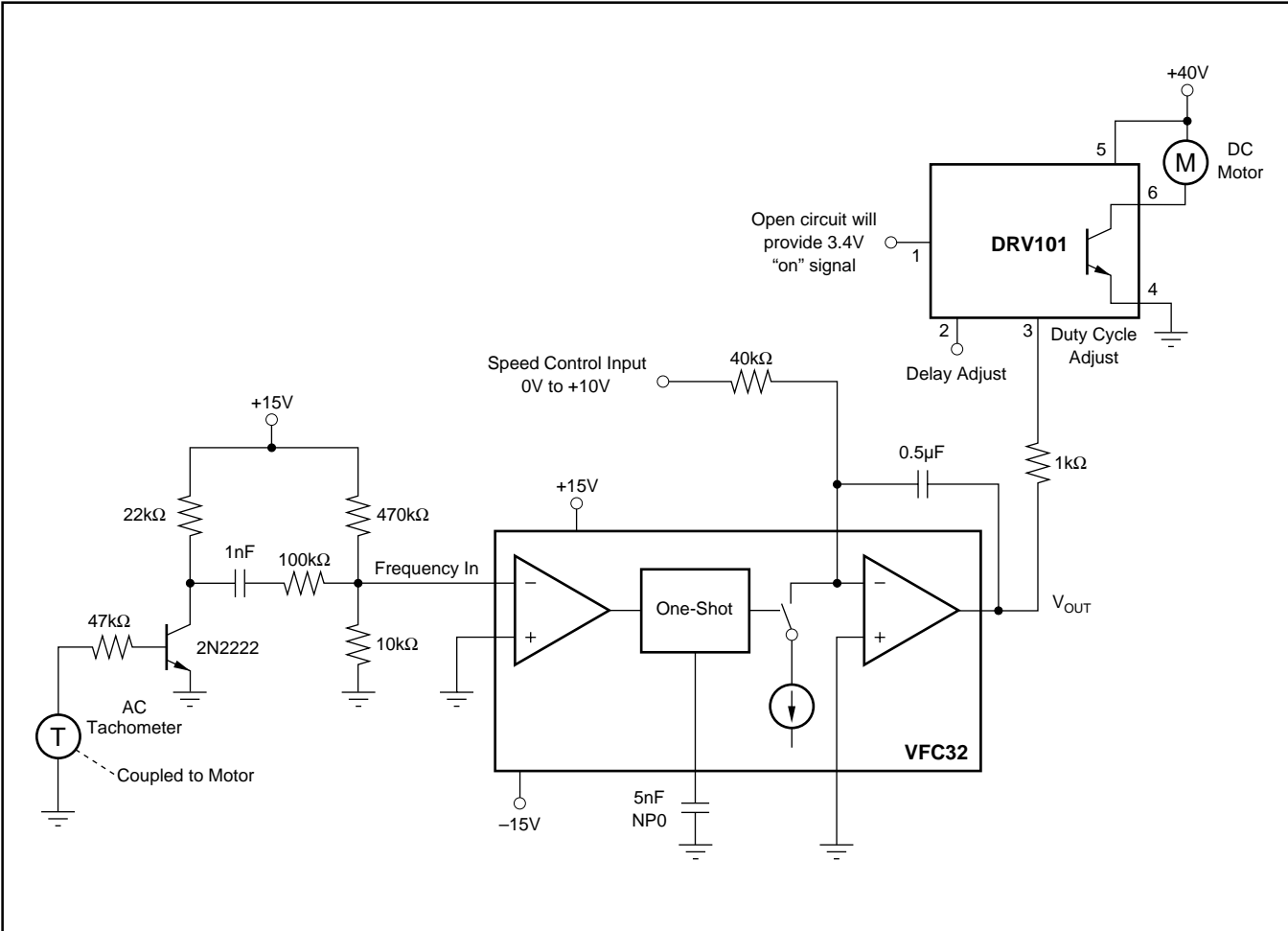

FIGURE 18. DC Motor Speed Control Using AC Tachometer.



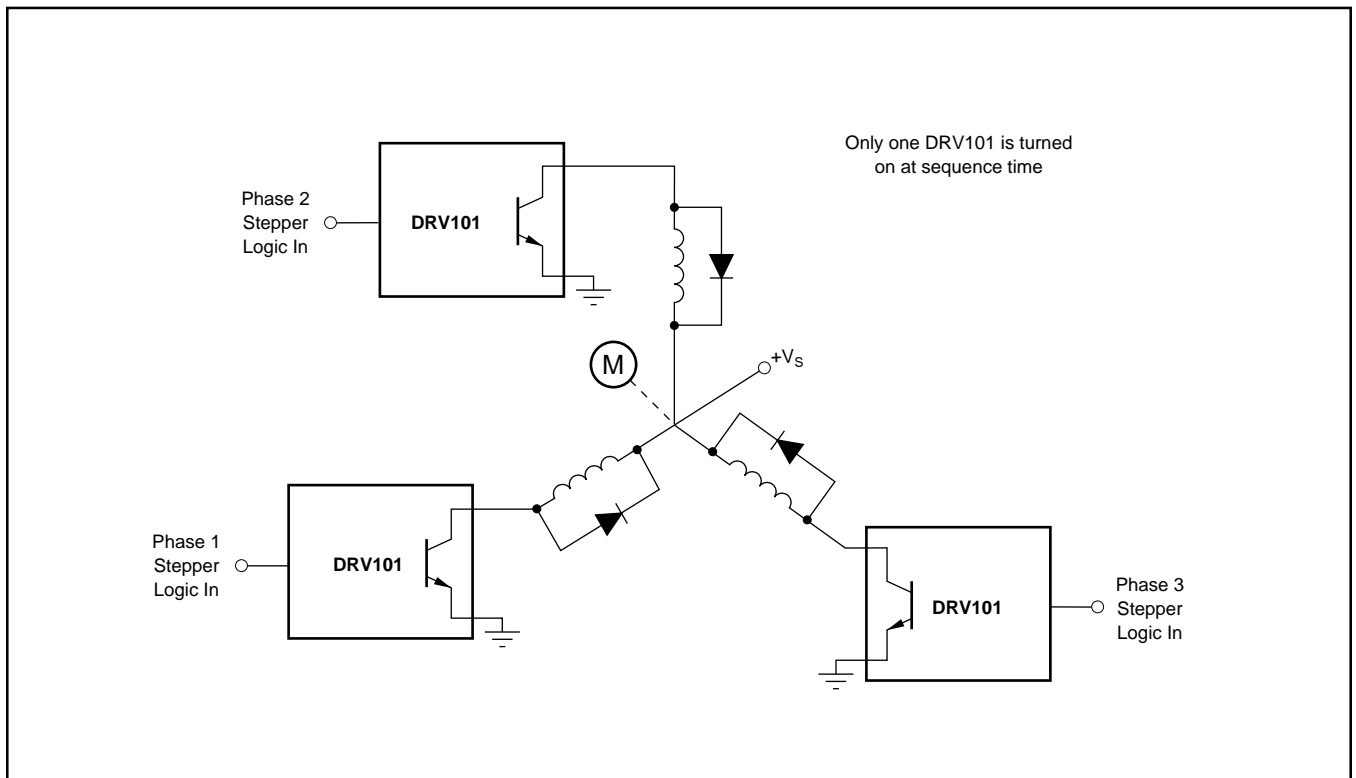

FIGURE 19. Three-Phase Stepper Motor Driver Provides High-Stepping Torque.

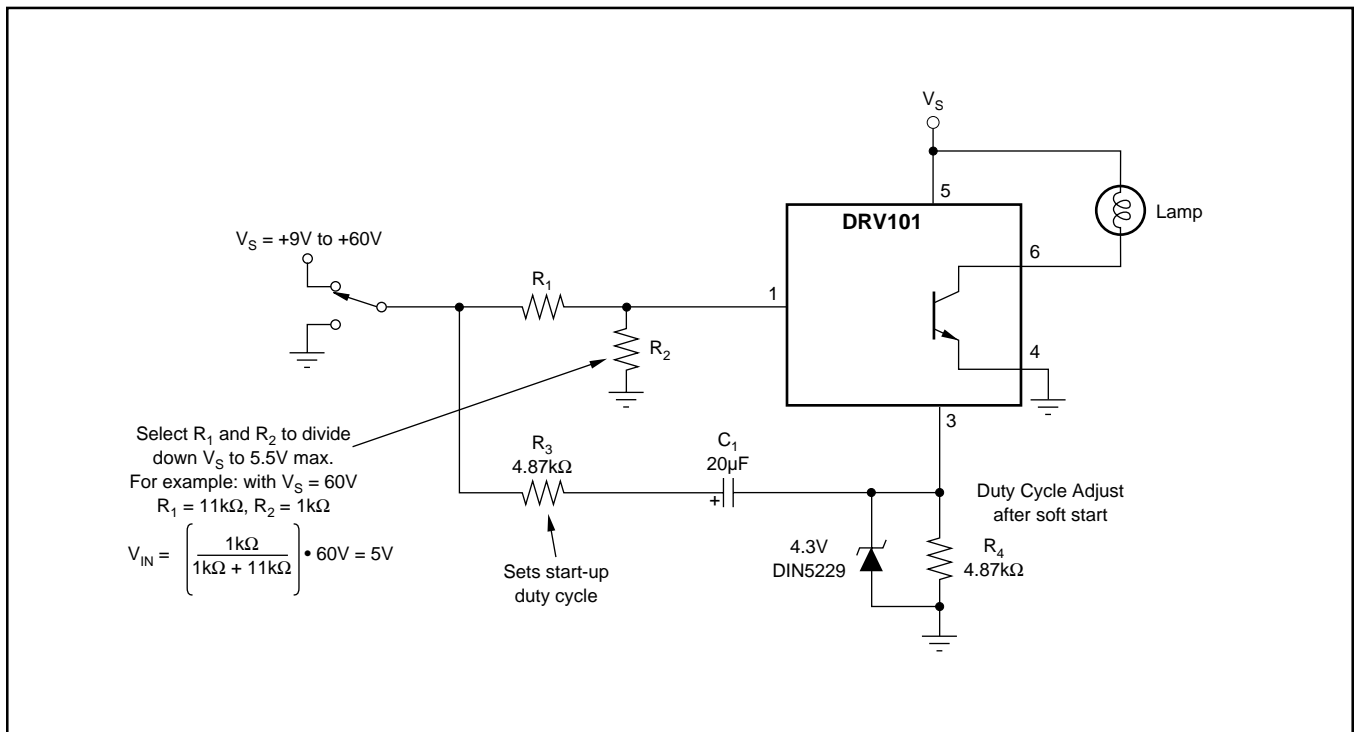

FIGURE 20. Soft-Start Circuit for Incandescent Lamps and Other Sensitive Loads.

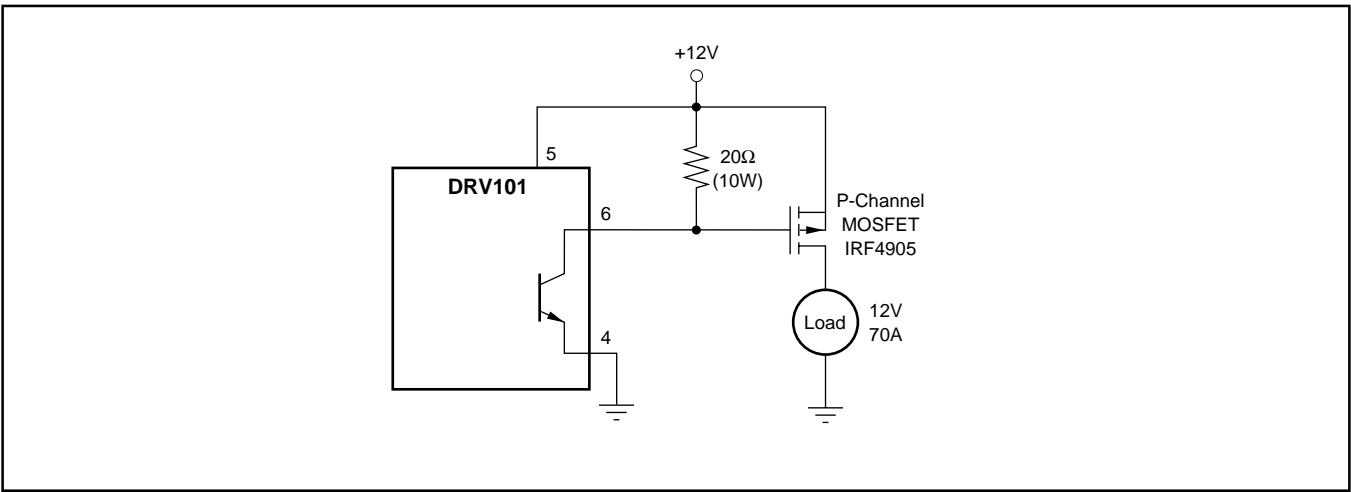

FIGURE 21. High Power, High-Side Driver.

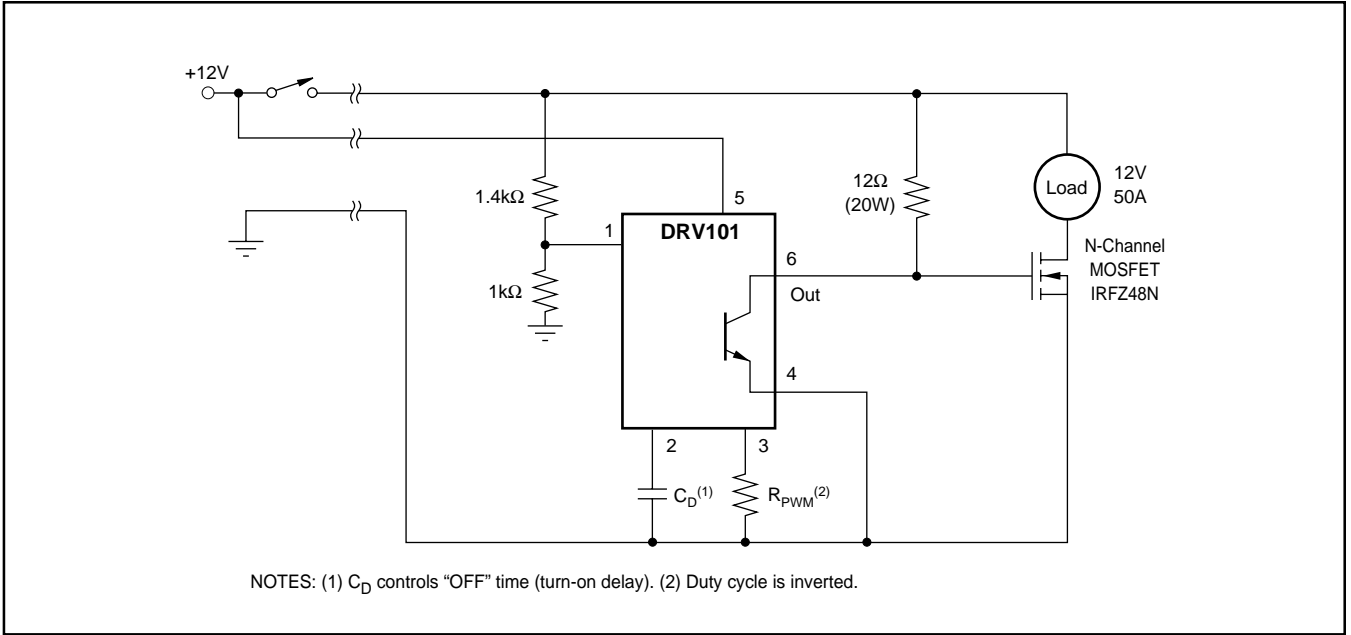

FIGURE 22. High Power, Time Delay, Low-Side Driver.

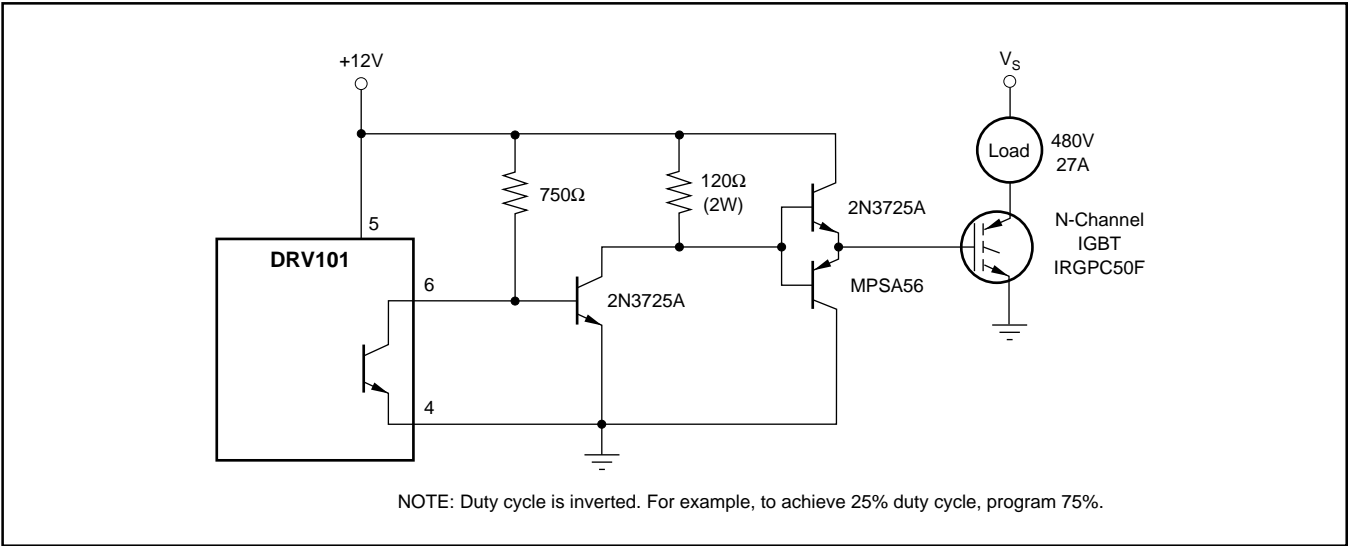

FIGURE 23. Very High Power, Low-Side Driver.

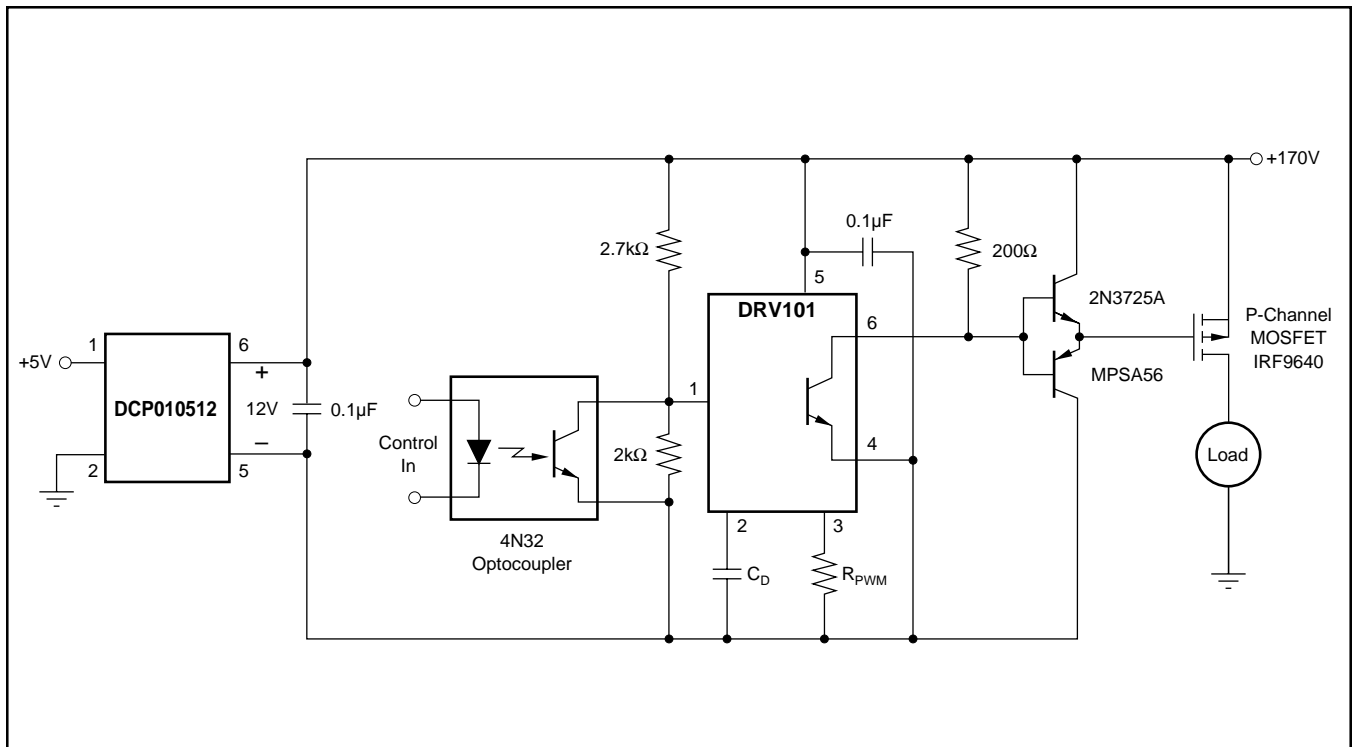

FIGURE 24. Isolated High-Side Driver.

## PACKAGING INFORMATION

ORDERABLE DEVICE	STATUS(1)	PACKAGE TYPE	PACKAGE DRAWING	PINS	PACKAGE QTY
DRV101F	OBSOLETE	PFM	KTW	7	
DRV101F/500	ACTIVE	PFM	KTW	7	500
DRV101FKTWT	ACTIVE	PFM	KTW	7	50
DRV101T	ACTIVE	TO/SOT	KC	7	49

(1) The marketing status values are defined as follows:

**ACTIVE:** Product device recommended for new designs.

**LIFEBUY:** TI has announced that the device will be discontinued, and a lifetime-buy period is in effect.

**NRND:** Not recommended for new designs. Device is in production to support existing customers, but TI does not recommend using this part in a new design.

**PREVIEW:** Device has been announced but is not in production. Samples may or may not be available.

**OBSOLETE:** TI has discontinued the production of the device.

---

## KTW (R-PSFM-G7)

## PLASTIC FLANGE-MOUNT

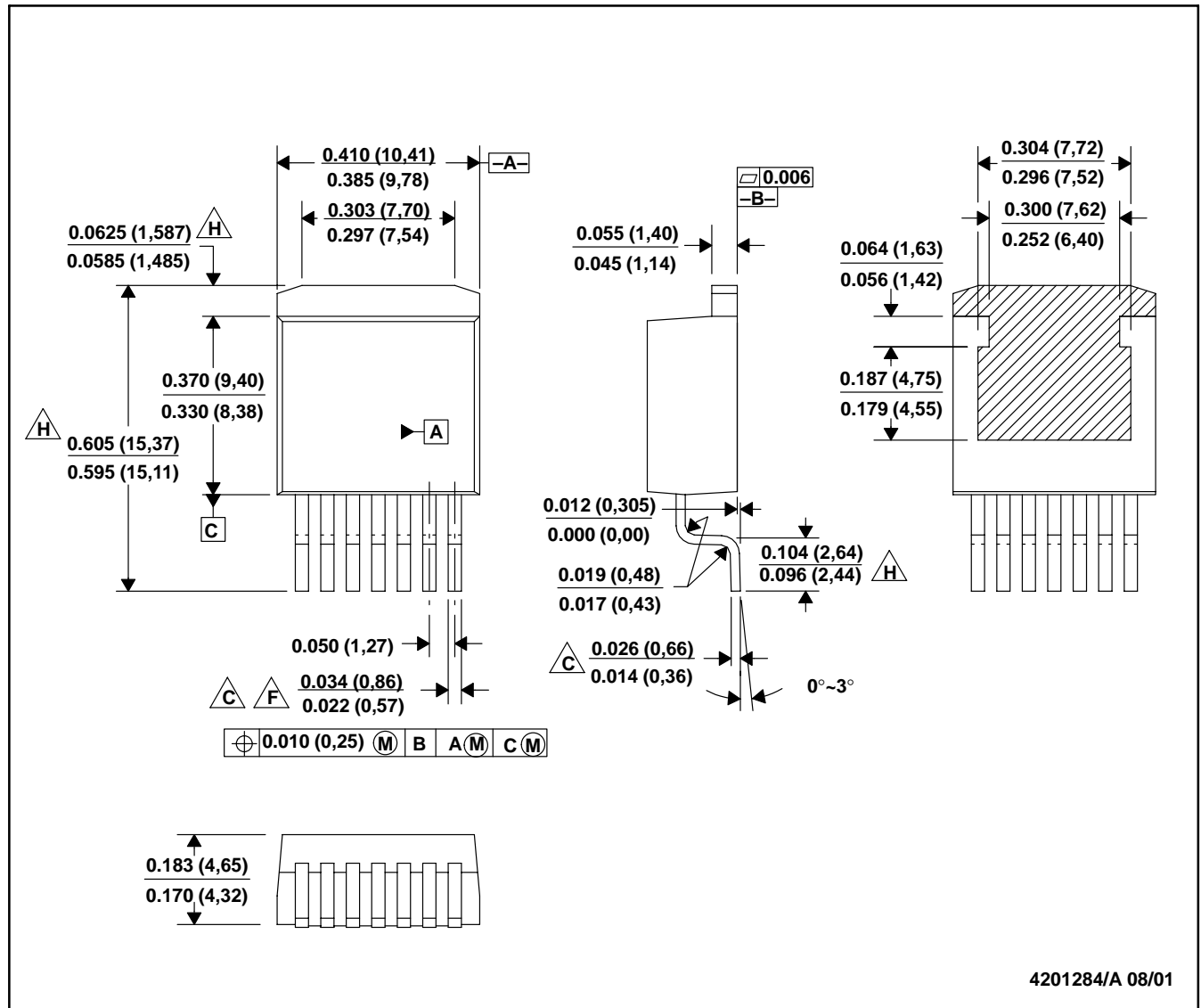

4201284/A 08/01

- NOTES:
- All linear dimensions are in inches (millimeters).
  - This drawing is subject to change without notice.
  - $\triangle C$ : Lead width and height dimensions apply to the plated lead.
  - Leads are not allowed above the Datum B.
  - Stand-off height is measured from lead tip with reference to Datum B.
  - $\triangle F$ : Lead width dimension does not include dambar protrusion. Allowable dambar protrusion shall not cause the lead width to exceed the maximum dimension by more than 0.003".
  - Cross-hatch indicates exposed metal surface.
  - $\triangle H$ : Falls within JEDEC MO-169 with the exception of the dimensions indicated.

KC (R-PSFM-T7)

PLASTIC FLANGE-MOUNT PACKAGE

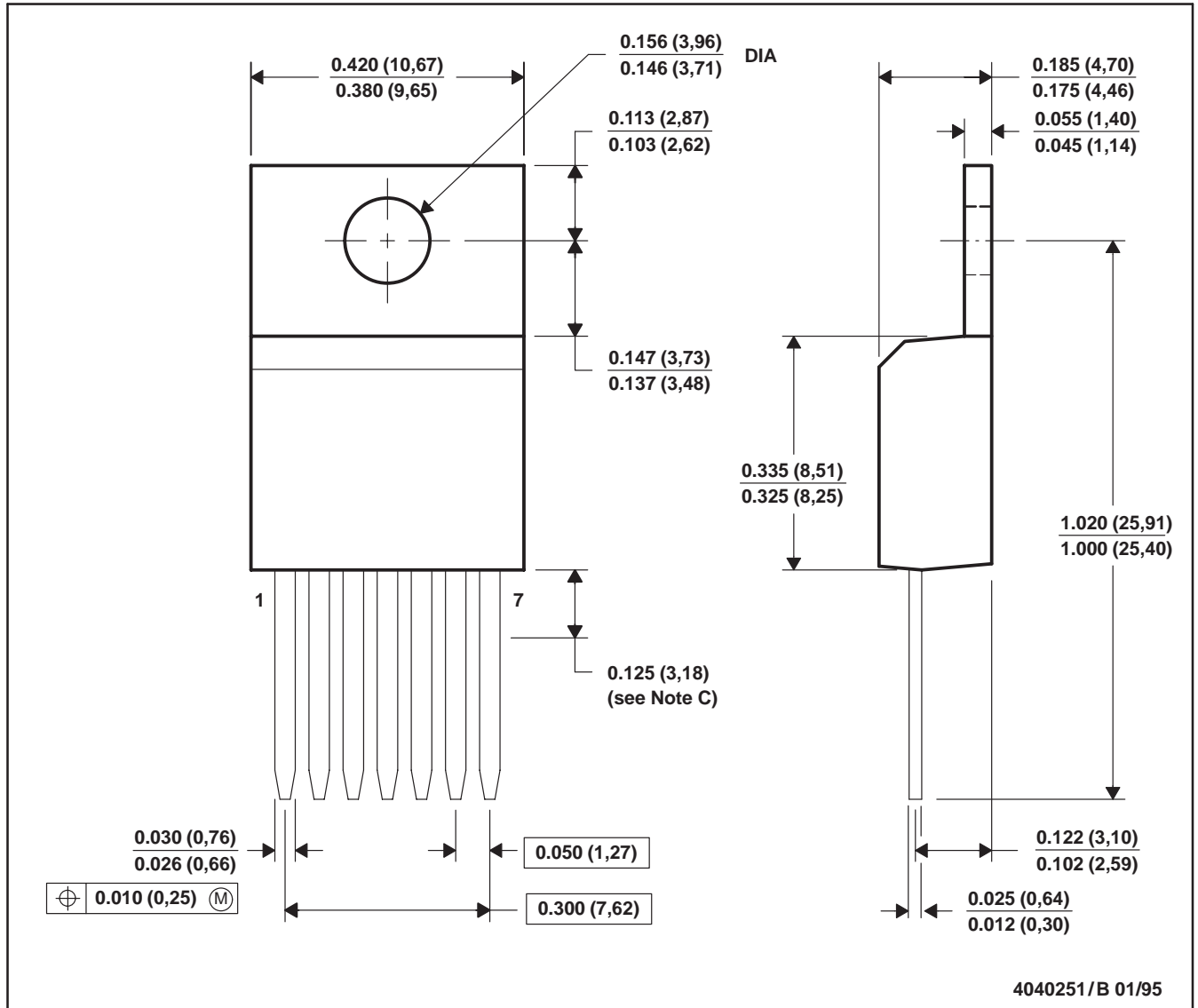

## IMPORTANT NOTICE

Texas Instruments Incorporated and its subsidiaries (TI) reserve the right to make corrections, modifications, enhancements, improvements, and other changes to its products and services at any time and to discontinue any product or service without notice. Customers should obtain the latest relevant information before placing orders and should verify that such information is current and complete. All products are sold subject to TI's terms and conditions of sale supplied at the time of order acknowledgment.

TI warrants performance of its hardware products to the specifications applicable at the time of sale in accordance with TI's standard warranty. Testing and other quality control techniques are used to the extent TI deems necessary to support this warranty. Except where mandated by government requirements, testing of all parameters of each product is not necessarily performed.

TI assumes no liability for applications assistance or customer product design. Customers are responsible for their products and applications using TI components. To minimize the risks associated with customer products and applications, customers should provide adequate design and operating safeguards.

TI does not warrant or represent that any license, either express or implied, is granted under any TI patent right, copyright, mask work right, or other TI intellectual property right relating to any combination, machine, or process in which TI products or services are used. Information published by TI regarding third-party products or services does not constitute a license from TI to use such products or services or a warranty or endorsement thereof. Use of such information may require a license from a third party under the patents or other intellectual property of the third party, or a license from TI under the patents or other intellectual property of TI.

Reproduction of information in TI data books or data sheets is permissible only if reproduction is without alteration and is accompanied by all associated warranties, conditions, limitations, and notices. Reproduction of this information with alteration is an unfair and deceptive business practice. TI is not responsible or liable for such altered documentation.

Resale of TI products or services with statements different from or beyond the parameters stated by TI for that product or service voids all express and any implied warranties for the associated TI product or service and is an unfair and deceptive business practice. TI is not responsible or liable for any such statements.

Following are URLs where you can obtain information on other Texas Instruments products and application solutions:

<b>Products</b>		<b>Applications</b>	
Amplifiers	<a href="http://amplifier.ti.com">amplifier.ti.com</a>	Audio	<a href="http://www.ti.com/audio">www.ti.com/audio</a>
Data Converters	<a href="http://dataconverter.ti.com">dataconverter.ti.com</a>	Automotive	<a href="http://www.ti.com/automotive">www.ti.com/automotive</a>
DSP	<a href="http://dsp.ti.com">dsp.ti.com</a>	Broadband	<a href="http://www.ti.com/broadband">www.ti.com/broadband</a>
Interface	<a href="http://interface.ti.com">interface.ti.com</a>	Digital Control	<a href="http://www.ti.com/digitalcontrol">www.ti.com/digitalcontrol</a>
Logic	<a href="http://logic.ti.com">logic.ti.com</a>	Military	<a href="http://www.ti.com/military">www.ti.com/military</a>
Power Mgmt	<a href="http://power.ti.com">power.ti.com</a>	Optical Networking	<a href="http://www.ti.com/opticalnetwork">www.ti.com/opticalnetwork</a>
Microcontrollers	<a href="http://microcontroller.ti.com">microcontroller.ti.com</a>	Security	<a href="http://www.ti.com/security">www.ti.com/security</a>
		Telephony	<a href="http://www.ti.com/telephony">www.ti.com/telephony</a>
		Video & Imaging	<a href="http://www.ti.com/video">www.ti.com/video</a>
		Wireless	<a href="http://www.ti.com/wireless">www.ti.com/wireless</a>

Mailing Address: Texas Instruments  
Post Office Box 655303 Dallas, Texas 75265

Copyright © 2003, Texas Instruments Incorporated