

This PIC development board has been designed to develop RS485 based and DMX512 applications, the board has 28 pin SMD Pic micro-controller, RS485 chip for communications, all I/O line has pull-up resistor which can be soldered as per application requirement on particular port pins. In-circuit programming of PIC micro-controller can be achieved via a 6-pin header that is compatible with the Microchip PICkit2 or PICkit3. On board 3.3 V and 5V DC regulators allows using 3V and 5V PICS, This board support both 3.3V low power and normal 5V operation, supply selection with jumper closure. All I/O pins supported with parallel GND and VCC header connector for easy interface of any device or sensor and also can be used as address setting jumper by pulling high or low Important for DMX512 Address.

On board Optically isolated gate driver and Mosfet make DC solid state relay , which can be used to drive High Power LED, Solenoid, DC Motor and any device required DC supply On off or PWM, the input of gate driver is open and has header connector to connect with any suitable I/O line using female header wire hookup. 3Pin screw terminal for easy interface of RS485 twisted cable including GND connections for cable screen, 4 Pin header connector for DC supply input, diode provided at input supply for reverse supply protection.

Logic Supply 7V to 12V DC @ 500mA

J1 Jumper for Supply Input Selection to PIC Micro 3.3V Or 5V

Screw Terminal for Load supply (Solid State Relay)

Load Supply 12V To 48 DC (VL & GND) CN17

Load 12V to 48V 5Amps (VL & OP) CN16

Operating Frequency Optically isolated Gate Driver up to 50 KHz

Duty Cycle (Gate Driver/Mosfet) 10 to 100%

Screw Terminal for Load

D1 Power LED

D3 Output LED

28 Pin Microchip SO28 SMD Micro-Controller with Internal Oscillator can be used

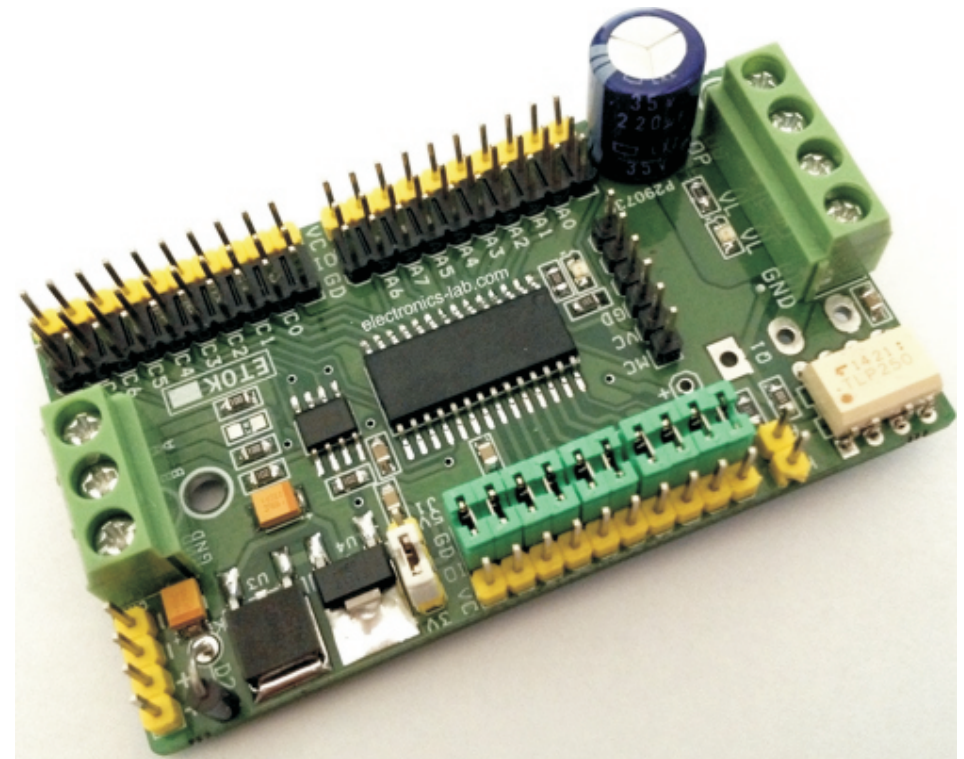

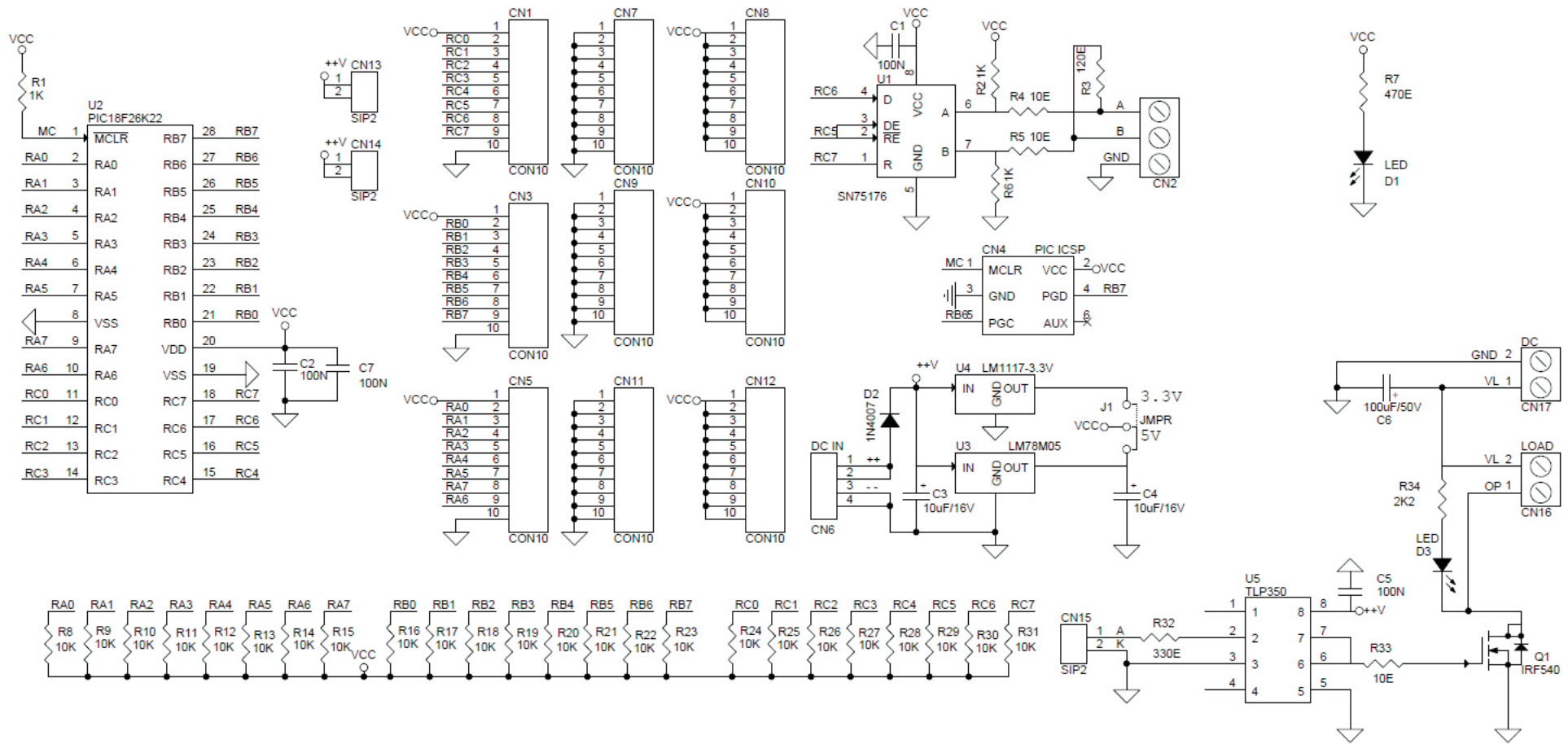



BOM			
SR.	QNTY.	REF.	DESC.
1	9	CN1,CN3,CN5,CN7,CN8,CN9,CN10,CN11,CN12	10 PIN HEADER CONNECTOR
2	1	CN2	3 PIN SCREW TERMINAL
3	1	CN4	6 PIN HEDAER CONNECTOR
4	1	CN6	4 PIN HEADER CONNECTOR
5	2	CN13,CN14	1 PIN HEADER CONNECTOR
6	1	CN16	2 PIN SCREW TERMINALS
7	1	CN17	2 PIN SCREW TERMINALS
8	4	C1,C2,C5,C7	0.1uF SMD 0805
9	2	C3,C4	10uF/16V SMD 1210
10	1	C6	100uF/50V
11	2	D1,D3	LED SMD 0805
12	1	D2	1N4007
13	1	J1	3 PIN JUMPER WITH CLOSURE
14	1	Q1	IRF540 SMD
15	3	R1,R2,R6	1K SMD 0805
16	1	R3	120E SMD 0805
17	3	R4,R5,R33	10E SMD 0805
18	1	R7	470E SMD 0805
19	24	R8 To R31	10K SMD 0805
20	1	R32	330E SMD 0805
21	1	R34	2K2 SMD 0805
22	1	U1	SN75176 SMD SO8
23	1	U2	PIC18F26K22 SMD SO28
24	1	U3	LM78M05 SMD DPAK
25	1	U4	LM1117-3.3V SMD
26	1	U5	TLP350 DIP/SMD
27	1	CN15	2 Pin Header Connector

