

1. Summary

1.1 .Brief Instruction

DFPLayer Mini module is a serial MP3 module provides the perfect integrated MP3, WMV hardware decoding. While the software supports TF card driver, supports FAT16, FAT32 file system. Through simple serial commands to specify music playing, as well as how to play music and other functions, without the cumbersome underlying operating, easy to use, stable and reliable are the most important features of this module.

1.2 .Features

- Support Mp3 and WMV decoding
- Support sampling rate of 8KHz,11.025KHz,12KHz,16KHz,22.05KHz,24KHz,32KHz,44.1KHz,48KHz
- 24-bit DAC output, dynamic range support 90dB, SNR supports 85dB
- Supports FAT16, FAT32 file system, maximum support 32GB TF card
- A variety of control modes, serial mode, AD key control mode
- The broadcast language spots feature, you can pause the background music being played
- Built-in 3W amplifier
- The audio data is sorted by folder; supports up to 100 folders, each folder can be assigned to 1000 songs
- 30 levels volume adjustable, 10 levels EQ adjustable.

1.3 .Application

- Car navigation voice broadcast
- Road transport inspectors, toll stations voice prompts
- Railway station, bus safety inspection voice prompts
- Electricity, communications, financial business hall voice prompts
- Vehicle into and out of the channel verify that the voice prompts
- The public security border control channel voice prompts
- Multi-channel voice alarm or equipment operating guide voice
- The electric tourist car safe driving voice notices
- Electromechanical equipment failure alarm
- Fire alarm voice prompts
- The automatic broadcast equipment, regular broadcast.

2. Module Application Instruction

2.1. Specification Description

Item	Description
MP3Format	1、 Support 11172-3 and ISO13813-3 layer3 audio decoding
	2、 Support sampling rate (KHZ):8/11.025/12/16/22.05/24/32/44.1/48
	3、 Support Normal、 Jazz、 Classic、 Pop、 Rock etc
UART Port	Standard Serial; TTL Level; Baud rate adjustable(default baud rate is 9600)
Working Voltage	DC3.2~5.0V; Type :DC4.2V
Standby Current	20mA
Operating Temperature	-40~+70
Humidity	5% ~95%

Table 2.1 Specification Description

2.2 .Pin Description

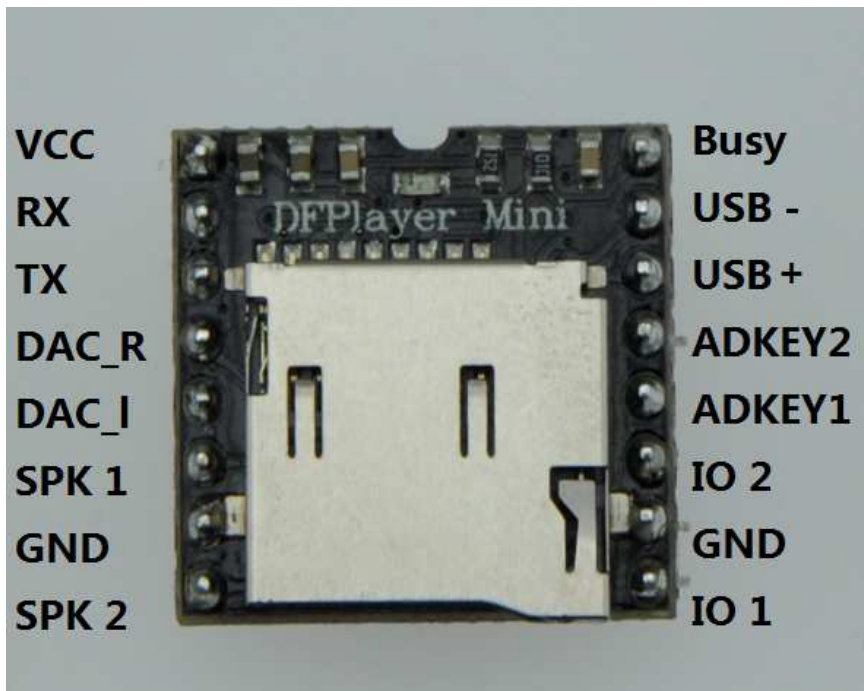

Figure 2.1

No	Pin	Description	Note
1	VCC	Input Voltage	DC3.2~5.0V;Type: DC4.2V
2	RX	UART serial input	
3	TX	UART serial output	
4	DAC_R	Audio output right channel	Drive earphone and amplifier
5	DAC_L	Audio output left channel	Drive earphone and amplifier
6	SPK2	Speaker-	Drive speaker less than 3W
7	GND	Ground	Power GND
8	SPK1	Speaker+	Drive speaker less than 3W
9	IO1	Trigger port 1	Short press to play previous (long press to decrease volume)
10	GND	Ground	Power GND
11	IO2	Trigger port 2	Short press to play next (long press to increase volume)
12	ADKEY1	AD Port 1	Trigger play first segment
13	ADKEY2	AD Port 2	Trigger play fifth segment
14	USB+	USB+ DP	USB Port
15	USB-	USB- DM	USB Port
16	BUSY	Playing Status	Low means playing \High means no

Table 2.2 Pin Description

3. Serial Communication Protocol

Serial port as a common communication in the industrial control field, we conducted an industrial level of optimization, adding frame checksum, retransmission, error handling, and other measures to significantly strengthen the stability and reliability of communication, and can expansion more powerful RS485 for networking functions on this basis, serial communication baud rate can set as your own, the default baud rate is 9600

3.1. Serial Communication Format

Support for asynchronous serial communication mode via PC serial sending commands

Communication Standard:9600 bps

Data bits :1

Checkout :none

Flow Control :none

Format: \$\$ VER Len CMD Feedback para1 para2 checksum \$O		
\$\$	Start byte 0x7E	Each command feedback begin with \$, that is 0x7E
VER	Version	Version Information
Len	the number of bytes after “Len”	Checksums are not counted
CMD	Commands	Indicate the specific operations, such as play / pause, etc.
Feedback	Command feedback	If need for feedback, 1: feedback, 0: no feedback
para1	Parameter 1	Query high data byte
para2	Parameter 2	Query low data byte
checksum	Checksum	Accumulation and verification [not include start bit \$]
\$O	End bit	End bit 0xEF

For example, if we specify play NORFLASH, you need to send: 7E FF 06 09 00 00 04 FF DD EF
Data length is 6, which are 6 bytes [FF 06 09 00 00 04]. Not counting the start, end, and verification.

3.2 .Serial Communication Commands

1).Directly send commands, no parameters returned

CMD	Function Description	Parameters(16 bit)
0x01	Next	
0x02	Previous	
0x03	Specify tracking(NUM)	0-2999
0x04	Increase volume	
0x05	Decrease volume	
0x06	Specify volume	0-30
0x07	Specify EQ(0/1/2/3/4/5)	Normal/Pop/Rock/Jazz/Classic/Base
0x08	Specify playback mode (0/1/2/3)	Repeat/folder repeat/single repeat/ random

0x09	Specify playback source(0/1/2/3/4)	U/TF/AUX/SLEEP/FLASH
0x0A	Enter into standby – low power loss	
0x0B	Normal working	
0x0C	Reset module	
0x0D	Playback	
0x0E	Pause	
0x0F	Specify folder to playback	1~10(need to set by user)
0x10	Volume adjust set	{DH= 1:Open volume adjust } {DL: set volume gain 0~31}
0x11	Repeat play	{1:start repeat play} {0:stop play}

2).Query the System Parameters

Commands	Function Description	Parameters(16 bit)
0x3C	STAY	
0x3D	STAY	
0x3E	STAY	
0x3F	Send initialization parameters	0 - 0x0F(each bit represent one device of the low-four bits)
0x40	Returns an error, request retransmission	
0x41	Reply	
0x42	Query the current status	
0x43	Query the current volume	
0x44	Query the current EQ	
0x45	Query the current playback mode	
0x46	Query the current software version	
0x47	Query the total number of TF card files	
0x48	Query the total number of U-disk files	
0x49	Query the total number of flash files	
0x4A	Keep on	
0x4B	Queries the current track of TF card	
0x4C	Queries the current track of U-Disk	
0x4D	Queries the current track of Flash	

3.3. Returned Data of Module

3.3.1. Returned Data of Module Power-on

1).The module power on, require a certain of the time initialization, this time is determined by U-disk, TF card, flash, etc. device 's file numbers, general situation in the 1.5 ~ 3Sec. If module initialization data has not been

DFPLayer Mini

sent out within the time, indicating that the module initialization error, please reset the module's power supply, and detect hardware connecting;

2).The module initialization data including online devices, such as sending 7E FF 06 3F 00 00 01 xx xx EF, DL = 0x01 describe only the U-disk online during power-on, Other data are seen as the table below:

U-Disk on-line	7E FF 06 3F 00 00 01 xx xx EF	Each device are or relationship
TF Card on-line	7E FF 06 3F 00 00 02 xx xx EF	
PC on-line	7E FF 06 3F 00 00 04 xx xx EF	
FLASH on-line	7E FF 06 3F 00 00 08 xx xx EF	
U-disk & TF Card on-line	7E FF 06 3F 00 00 03 xx xx EF	

3).MCU will not send corresponding control commands until module initialization sending commands or the module will not process the commands sent by MCU, and will also affect the normal initialization of the module.

3.3.2 .Returned Data of Track Finished Playing

U-Disk finish playback 1st track	7E FF 06 3C 00 00 01 xx xx EF
U-Disk finish playback 2nd track	7E FF 06 3C 00 00 02 xx xx EF
TF card finish playback 1st track	7E FF 06 3D 00 00 01 xx xx EF
TF card finish playback 2nd track	7E FF 06 3D 00 00 02 xx xx EF
Flash finish playback 1st track	7E FF 06 3E 00 00 01 xx xx EF
Flash finish playback 2nd track	7E FF 06 3E 00 00 02 xx xx EF

1.The module will enter into pause status automatically after being specified playing, if customers need such application, they can specify track to play ,the module will enter into pause status after finishing playing ,and wait for the commands sent by MCU.

2 In addition, we opened a dedicated I/O as decoding and pausing status indication. See Pin 16, Busy

1).Output high level at playback status;

2).Output low level at pause status and module sleep;

3. For continuous playback applications, it can be achieved as below, if it finishes the first tracking of the TF card, it will return

7E FF 06 3D 00 00 01 xx xx EF
3D ---- U-disk command
00 01 ---- expressed finished playing tracks.

If the external MCU receives this command, please wait 100ms. And then sending the playback command [7E FF 06 0D 00 00 00 FF EE EF], because inside the module it will first initialize the next track information. In this case, the module can be played continuously.

4. If the currently finish playing the first song, the track pointer automatically point to second song, If you send a "play the next one" command, then the module will playback the third song. And, if the module finishes playing the last one, the player will automatically jump to the first pointer, and pause.

5. After specifying device, the module play pointer will point to device root directory of the first track, and enters the pause state, and wait MCU sending track playing command.

3.3.3 .Returned Data of Module Responds

FLASH finish play the 1 st track	7E FF 06 3E 00 00 01 xx xx EF
---	-------------------------------

1). in order to strengthen the stability of the data communication, we have increased response processing; ACKB byte is set whether need to reply to response. So that to ensure each communication get handshake signals, which will indicate the module has been successfully received data sent by the MCU and process immediately.

2).For general applications, customers can freely choose, without this response processing is also ok.

3.3.4 .Returned Data of Module Error

Module is busy	7E FF 06 40 00 00 00 xx xx EF
A frame data are not all received	7E FF 06 40 00 00 01 xx xx EF
Verification error	7E FF 06 40 00 00 02 xx xx EF

1). In order to strengthen the stability of the data communication, we added data error handling mechanism. Module will responds information after receiving error data format;

2). In the case of relatively harsh environment, it is strongly recommended that customers process this command. If the application environment in general, you no need handle it;

3).The module returns busy, basically when module power-on initialization will return, because the modules need to initialize the file system.

3.3.5. Push-in and Pull-out information of Device

Push in U-disk	7E FF 06 3A 00 00 01 xx xx EF
Push in TF card	7E FF 06 3A 00 00 02 xx xx EF
Pull out U-disk	7E FF 06 3B 00 00 01 xx xx EF
Pull out TF card	7E FF 06 3B 00 00 02 xx xx EF

1).For the flexibility of the module, we particularly add command feedback of push-in and pull-out device. Let user know the working status of the module.

2).When push-in device, we default playback the first track of device root directory as audition, if users do not need this feature, you can wait 100ms after receiving the message of push –in serial device ,and then send pause command.

3.4 Serial Commands

3.4.1. Commands of Specify Track Play

Our instructions are given in support of the specified track is playing, the song selection ranges from 0 to 2999. Actually can support more, because it involves the reasons to the file system, support for the song too much, it will cause the system to operate slowly, and usually the application does not need to support so many files. If the customer has unconventional applications, please communicate with us in advance.

1).For example, select the first song played, serial transmission section: 7E FF 06 03 00 00 01 FF E6 EF
7E --- START command
FF --- Version Information
06 --- Data length (not including parity)
03 --- Representative No.
00 --- If need to acknowledge [0x01: need answering, 0x00: do not need to return the response]
00 --- Tracks high byte [DH]
01 --- Tracks low byte [DL], represented here is the first song played
FF --- Checksum high byte
E6 --- Checksum low byte
EF --- End Command

2).For selections, if choose the 100th song, first convert 100 to hexadecimal, the default is double-byte, it is 0x0064.

DH = 0x00; DL = 0x64

3).If you choose to play the 1000th, first convert 1000 to hexadecimal, the default is double-byte, it is 0x03E8
DH = 0x03; DL = 0xE8

4).And so on to the other operations, as in the embedded area in hexadecimal is the most convenient method of operating.

3.4.2 .Commands of Specify Volume

1). Our system power-on default volume is 30, if you want to set the volume, then directly send the corresponding commands.

2).For example, specify the volume to 15, serial port to send commands: 7E FF 06 06 00 00 0F FF D5 EF

3).DH = 0x00; DL = 0x0F, 15 is converted to hexadecimal 0x000F, can refer to the instructions of playing track section.

3.4.3 .Specify Device Play

1).The module default support four types of playback devices, the device must be on line, so it can specify playback. The software will automatically detect without user attention.

2).Refer the table as below to select the appropriate command to send

3).Module will automatically enter the Suspend state after the specified device, waiting for the user to specify a track playing. It will take about 200ms from specifying device to the module initialize file information. Please wait for 200ms and then send the specified track command.

Specify playback device -U-disk	7E FF 06 09 00 00 01 xx xx EF	xx xx: Verification
Specify playback device -TF Card	7E FF 06 09 00 00 02 xx xx EF	
Specify playback device -SLEEP	7E FF 06 09 00 00 05 xx xx EF	

3.4.4. Specify File to Play

Specify folder 01 of 001.mp3	7E FF 06 0F 00 01 01 xx xx EF
Specify folder 11 of 100.mp3	7E FF 06 0F 00 0B 64 xx xx EF
Specify folder 99 of 255.mp3	7E FF 06 0F 00 63 FF xx xx EF

1).Specify the folder playback is developed extensions, default folders are named as "01", "11" in this way because our module does not support Chinese characters identify the name of the folder name, in order to stabilize the system switching speeds and songs under each folder default maximum support up to 255 songs, up to 99 folders classification, if customers have special requirements, they need to classify according to the English name, we also can be achieved, but name only is "GUSHI", "ERGE" and other English name.

2).For example, specify "01" folder 100.MP3 file, serial port to send commands : 7E FF 06 0F 00 01 64 xx xx EF

DH: represents the name of the folder, the default support for 99 documents become 01 - 99 named

DL: on behalf of the tracks, the default maximum of 255 songs that 0x01 ~ 0xFF

Please refer to the above set rules for setting tracks



3).to the standard of the module, you must specify both the folder and file name, to lock a file. Individually specified folder or specify the file name alone is also possible, but the document management will be worse.

4).The following diagram illustrates both the folders and file names are specified.

	01	2014/4/9 15:03	文件夹
	11	2014/4/9 15:00	文件夹
	31	2014/4/9 15:00	文件夹
	99	2014/4/9 15:00	文件夹

folder name reference

Figure 3.1 folder name

	001.mp3	2014/4/9 15:02	MP3 音频
	002.mp3	2014/4/9 15:03	MP3 音频
	255.mp3	2014/4/9 15:03	MP3 音频

file name reference

Figure 3.2 file name

3.5. Key Ports

We use the AD module keys, instead of the traditional method of matrix keyboard connection, it is to take advantage of increasingly powerful MCU AD functionality, Our module default configuration 2 AD port, 20 key resistance distribution, if used in strong electromagnetic interference or strong inductive, capacitive load of the occasion, please refer to our "Notes."

1).Refer diagram

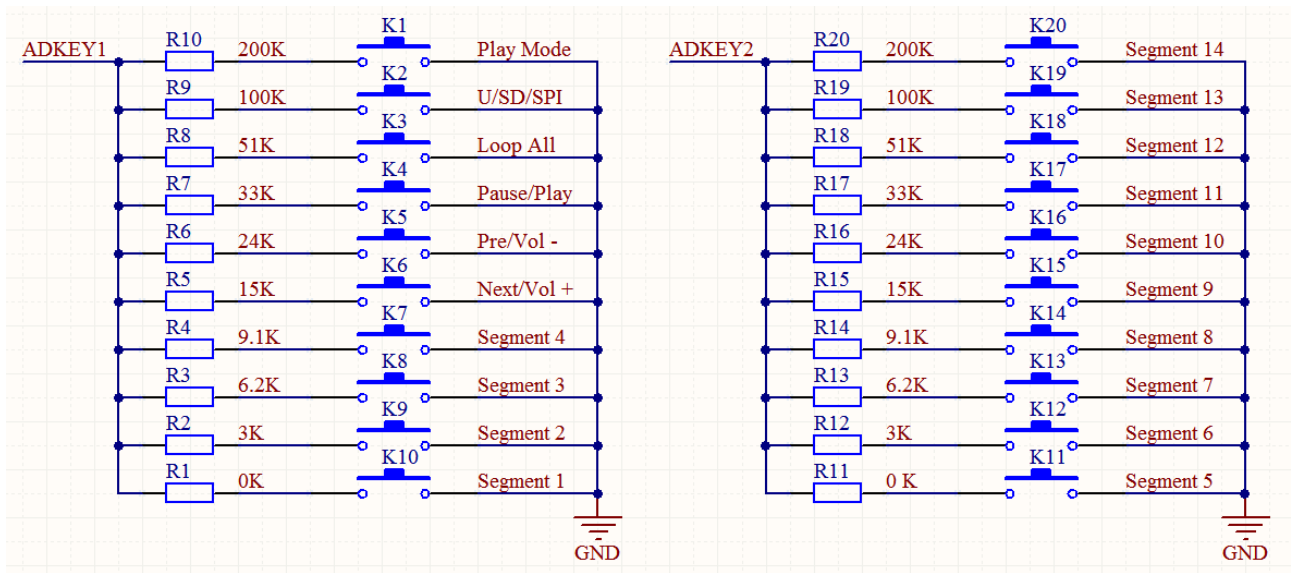

Figure 3.3 ad key refer

2)、20 function keys allocation table

Key	Short Push	Long Push	Description
K1	Play Mode		Switch to interrupt / non interrupted
K2	Playback device switches		U/TF/SPI/Sleep
K3	Operating Mode		All cycle
K4	Play/Pause		
K5	Previous	Vol+	
K6	Next	Vol-	
K7	4	Repeat play tracking 4	Long push always to repeat play
K8	3	Repeat play tracking 3	Long push always to repeat play

K9	2	Repeat play tracking 2	Long push always to repeat play
K10	1	Repeat play tracking 1	Long push always to repeat play
K11	5	Repeat play tracking 5	Long push always to repeat play
K12	6	Repeat play tracking 6	Long push always to repeat play
K13	7	Repeat play tracking 7	Long push always to repeat play
K14	8	Repeat play tracking 8	Long push always to repeat play
K15	9	Repeat play tracking 9	Long push always to repeat play
K16	10	Repeat play tracking 10	Long push always to repeat play
K17	11	Repeat play tracking 11	Long push always to repeat play
K18	12	Repeat play tracking 12	Long push always to repeat play
K19	13	Repeat play tracking 13	Long push always to repeat play
K20	14	Repeat play tracking 14	Long push always to repeat play

4、Application Circuit

4.1 Serial Communication Connect

Module's serial port is 3.3V TTL level, so the default interface level is 3.3V. If the MCU system is 5V. It is recommended connect a 1K resistor in series.

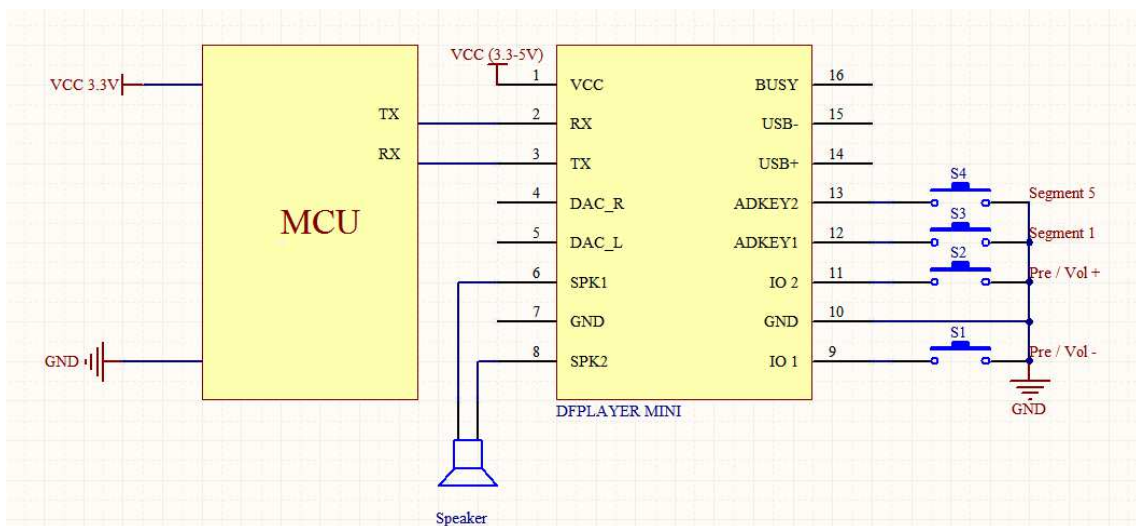

Figure 4.1 Serial Connect (3.3V)

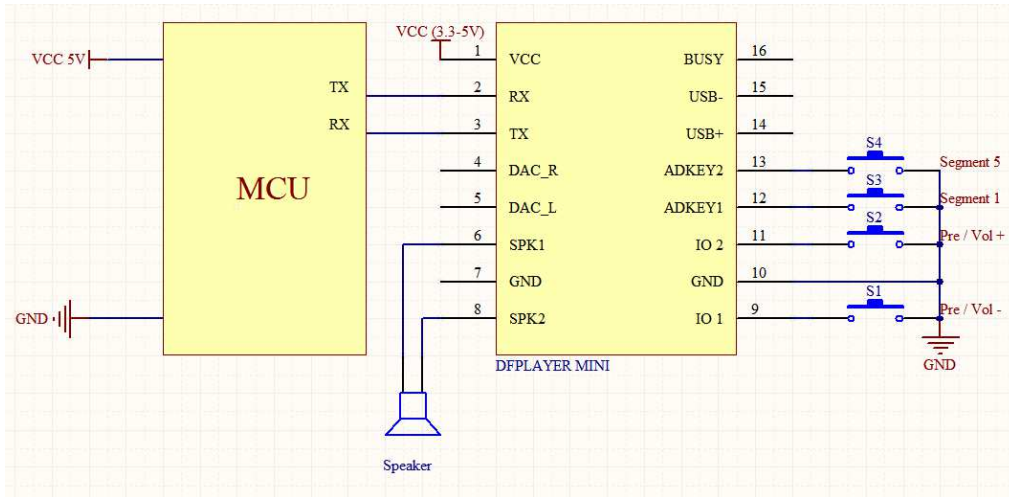

Figure 4.2 Serial Connect (5v)

4.2. Other Refer Diagram

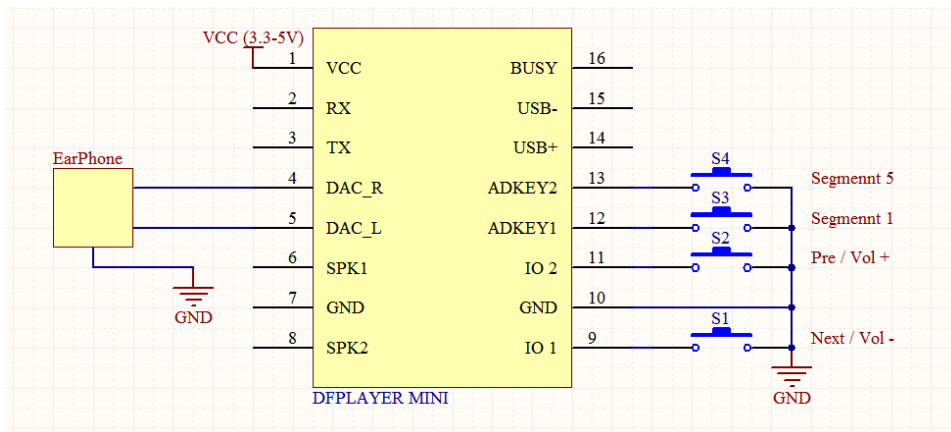

Figure 4.3 headset connect module

Between the headset and the module can string a 100R resistor, make a limiting

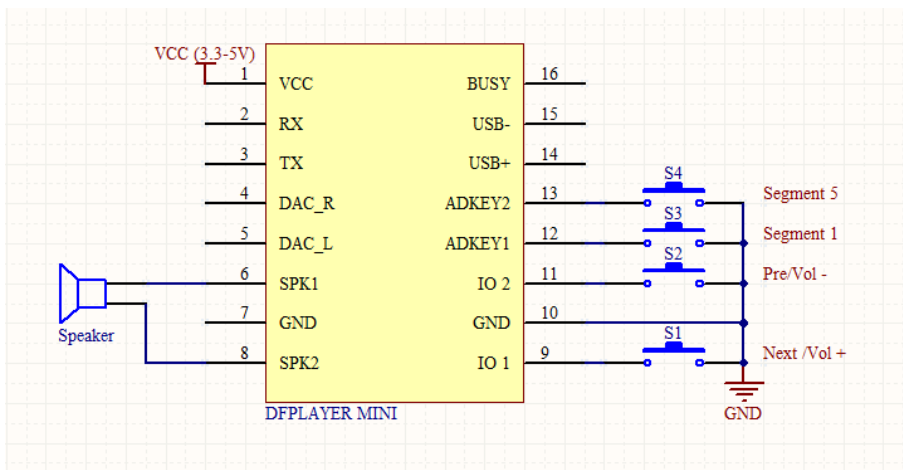

Figure 4.4 speaker connect module

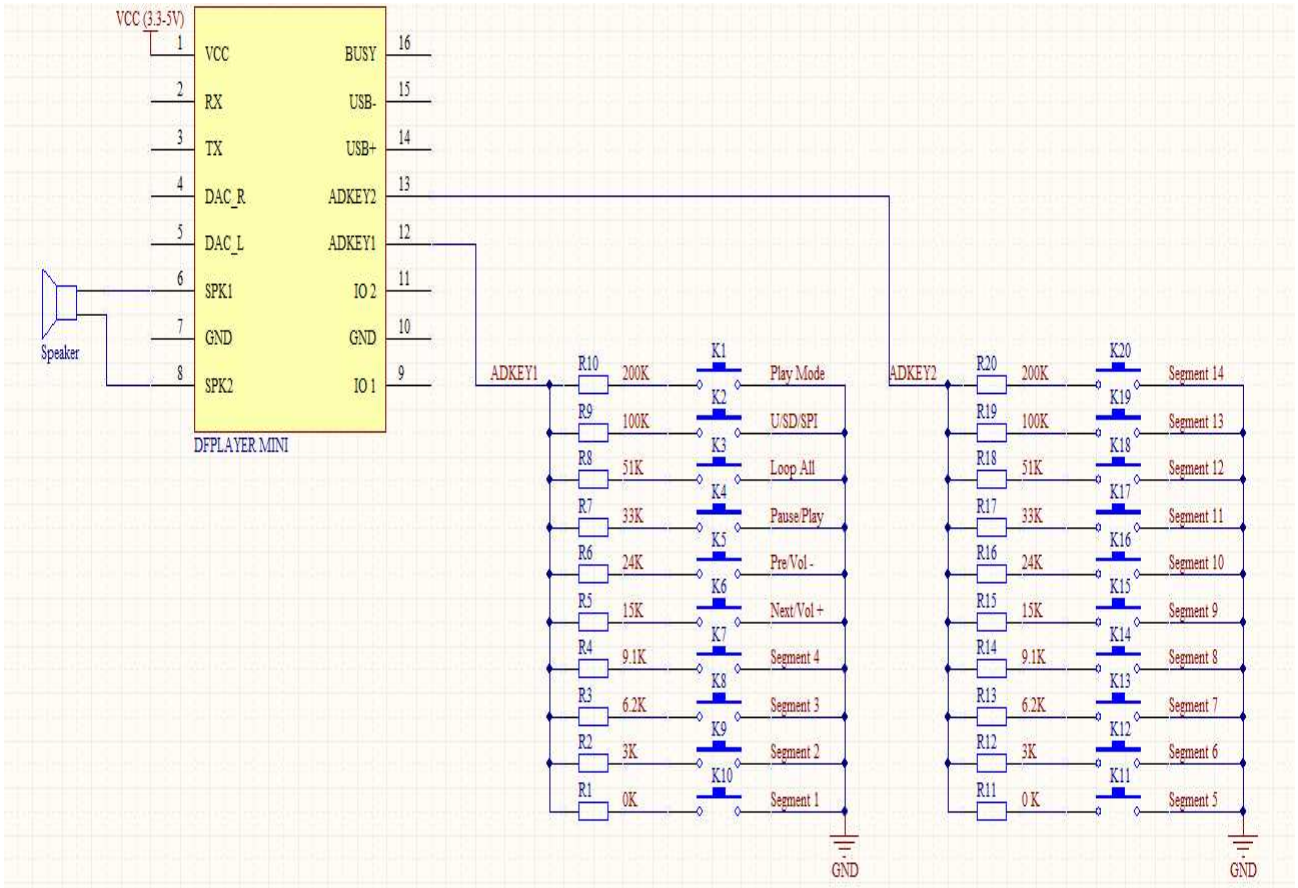

Figure 4.5 Ad key connect refer

5、MP3-TF-16P Size (unit: mm)

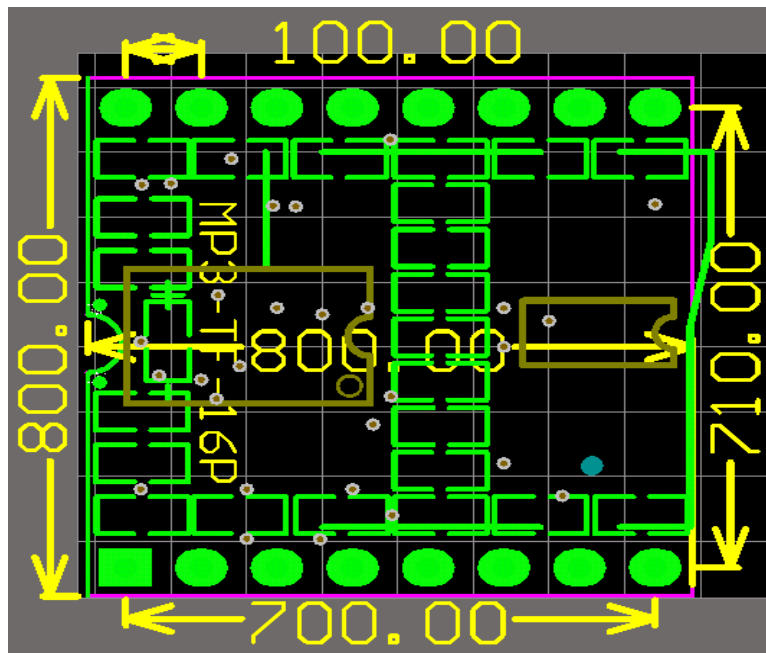

Figure 5.1 pcb size

6、 Note*

I/O Input Specification						
Item	Description	Min	Type	Max	Unit	Test Condition
VIL	Low-Level Input Voltage	-0.3	-	0.3*VDD	V	VDD=3.3V
VIH	High-Level Input Voltage	0.7VDD	-	VDD+0.3	V	VDD=3.3V
I/O Output Specification						
Item	Description	Min	Type	Max	Unit	Test Condition
VOL	Low-Level Output Voltage	-	-	0.33	V	VDD=3.3V
VOH	High-Level Output Voltage	2.7	-	-	V	VDD=3.3V

1. The module's external interfaces are 3.3V TTL level, so please note the level conversion during the hardware circuit design, also in strong interference environment, electromagnetic compatibility note some protective measures, GPIO using opt coupler isolation, increasing TVS etc.

2, ADKEY key values are in accordance with the general use of the environment, if the strong inductive or capacitive load environment, please note that the module power supply is recommended to use a separate isolated power supply, another matched beads and inductors for power filtering, we must ensure that the input power as much as possible the stability and clean. If you really can not be guaranteed, please contact us to reduce the number of keys to redefine wider voltage distribution.

3. For general Serial communication, please pay attention to level conversion. If strong interference environment, or long distance RS485 applications, then please note that signal isolation, in strict accordance with industry standard design communication circuits.