

## **0-30V / 0-3A Bench Power Supply Unit Troubleshooting FAQ's**

A collection of highlights of pages 1 – 147

### **Notes.....**

The original project was a kit from Greece. It has many errors that causes the power supply to fail because the supply voltage for the opamps exceeds their max allowed supply voltage, the transformer and output transistor are overloaded and the old driver transistor is severely overloaded. Its rectifier diodes and some of its resistors are also overloaded.

It cannot produce 30VDC at 3A. Its maximum output is 24V-25VDC with lots of ripple at 3A.

Therefore the reason for this upgraded version from reader's, experimenter's and professional's contributions.

### **Notes.....**

The difference between a 3Amp project and a 5Amp project:

1). The minimum transformer voltage for the latest version of this project is 28V and the maximum voltage is 30V.

The 28V transformer must be 120VA for the 3A project and it must be 198VA for the 5A project.

$28V \times 4.3A = 120VA$ ;  $28V \times 7.1A = 198VA$

(Don't assume this.....  $28V \times 3A = 84VA$  or  $28V \times 5A = 140VA$ ; a little transformer will be overloaded).

The current from the transformer will be 4.2A when the project has a 3A DC load.

The current from the transformer will be 7.1A when the project's output is 5A DC.

2). The 3A version uses two output transistors with emitter resistors.

The 5A version uses three output transistors with emitter resistors.

3). R7 is 0.47 ohms/10W for 3A

R7 is 0.27 ohms/10W for 5A.

4). The heatsink for the output transistors must be able to dissipate 110W for 3A.

The heatsink for the output transistors must be able to dissipate 183W for 5A.

### **Notes.....**

The MC34071 is made by Motorola/ON Semi/Freescale Semi which is one of the largest semiconductor manufacturers in the world.

The TLE2141 is made by Texas Instruments which is also one of the largest semiconductor manufacturers in the world.

These opamps were chosen because their max allowed total supply is 44V (+/-22V) and their inputs work without a negative supply voltage, and their outputs go much lower than ordinary opamps.

### **Notes.....**

This project uses a max power of  $3A \times 40V = 120W$  from the mains. So if your mains is 120V then a 1A fuse might blow so use a 1.5A slow-blow fuse.

If your mains is 240V then use a 0.75A slow-blow fuse.

A fast-blow fuse will blow trying to charge the huge filter capacitor at initial switch-on.

### **Notes.....**

Opamp U3 is the current regulator.

The 0.47 ohm resistor R7 develops a voltage across it due to the load current in it, and this voltage feeds the (-) input of U3. The (+) input of U3 is fed a variable voltage set by the current regulation pot P2. When the voltage from R7 is higher than the voltage set by the pot, the output voltage of U3 drops (comparator function), which causes D9 to reduce the voltage of the project until the load current is reduced to the setting. When the voltage at the output of U3 drops it turns on Q3 which lights the LED to warn that the current regulator is reducing the output voltage.

When you turn the current adjust pot P2, measure the output voltage of opamp U3. It should stay high at about +22V so it cannot cause D9 to reduce the voltage at the input of opamp U2.

With no load on the project, the output pin 6 of U3 should always be high at about +24V to +28V. So it does not reduce the output voltage through D9 (reverse-biased) and it does not turn on Q3 to light the LED.

The slider of the current adjusting pot P2 applies a small positive voltage to the (+) input pin 3 of U3.

The voltage should be +0.005V when P2 is turned to minimum and should be +1.414V when P2 is turned to maximum. Without a load, there is no voltage across R7 so the (-) input pin 2 is 0V. Then the output pin 6 of U3 should always be high.

**Notes.....** Only U3 uses the -1.3V supply because its output must go a little negative due to the forward voltage drop of D9 when the output of the project is shorted. If the output is shorted then there will be a fairly high current in R7 causing the (-) input of U3 to be higher than its (+) input so its output goes low enough that D9 reduces the input voltage to U2 to almost zero. D9 has a forward voltage drop of about 0.7V so the output of U3 must be able to go a little below -0.7V. I used two diodes to

make the negative supply for U3 at about -1.3V.

A 3V zener diode or even a 5.6V zener diode can be used instead of the two diodes.

**Notes.....** The BD139 powers the load if the two 2N3055 output transistors are shorted, are wired wrong or their 0.33 ohm emitter resistors have a value much too high. Then it will burn. If the 2N3055 output transistors have minimum gain then the max current in the BD139 is 75mA and is 38mA when the 2N3055 transistors have typical gain. Then when the output voltage is 18V the BD139 has about 22V across it, then it dissipates  $38\text{mA} \times 22\text{V} = 0.8\text{W}$  to  $75\text{mA} \times 22\text{V} = 1.7\text{W}$  which is not much. With a little heatsink it will be fine but without a heatsink its junction will be above its allowed max temperature.

**Notes.....** The transformer is 28VAC and 4.3A. Then without a load it produces a rectified and filtered voltage of about +39.6VDC.

U1 has a quiescent current of 3.5mA for a TLE2141, then its quiescent dissipation is  $39.6\text{V} \times 3.5\text{mA} = 139\text{mW}$ . Its output voltage is 11.2V and its output current is 5.6mA so it has  $39.6\text{V} - 11.2\text{V} = 28.4\text{V}$  across its output. Its output power dissipation is  $28.4\text{V} \times 5.6\text{mA} = 159\text{mW}$ . Then its total dissipation is  $139\text{mW} + 159\text{mW} = 298\text{mW}$  which is far from its maximum allowed dissipation of 1000mW at room temperature ambient. It will be warm, not too hot.

If the driver and output transistors work properly then U2 has a low output current and will be warm but should not get hot.

**Notes.....**

The TLE2141 opamp for U1 has a typical current of 3.5mA when warm and a max current of 4.5mA. The zener diode D8 adds 5.6mA to the current in U1 so its total current is 9.1mA to 10.1mA. Then the voltage across your R7 is 2.5mV to 2.7mV which is nothing. The input offset voltage of U1 is a max of only 1.4mV.

**Notes.....** R16 turns off the output transistor, and does it quickly.

Without it, the project's output voltage would probably rise if it is powering a low-current load, because of the leakage current in Q2 and Q4. The leakage current is fairly high because the transistors operate hot in this project.

R16 speeds-up the turn off because it discharges the capacitance of Q4 quickly.

The collector-base junction of a transistor has a small leakage current that increases when the temperature increases. The current gain of a transistor amplifies the resulting base current which turns on the transistor. R16 shunts the collector-base leakage current away from the base.

---

**Q:** Is it normal to have 45V at the + and - of the bridge diode?

**A:** Your 28V AC transformer might produce 30VAC when it has low load current. 30V AC RMS produces 42.4V peak. The rectifier bridge voltage drop reduces it to 41.0VDC. Your 45V is a little too high but is OK for opamp U3 if the 10V zener diode that feeds it is not connected backwards. The cathode of the zener diode is marked with a black bar and must be connected to the positive supply. Then the positive supply pin 7 of the opamp will be +31V which is well below its maximum allowed voltage of 44V. Yours might be +35V which is also fine.

The 10V zener diode D13 passes 7mA for the LED and 3.5mA for opamp U3, so its max current is 10.5mA and it dissipates  $10\text{V} \times 10.5\text{mA} = 105\text{mW}$ . A 0.5W or 1W zener diode will be fine.

1N758A, 1N961B, 1N5240B, 1N6000B or many BZX European ones.

P2 is 10k, R18 is 33k and the current-calibration trimpot is about 45k. The trimpot connects to the output of U1 which is +11.2V. Then if P2 connects pin 3 input of U3 to R18 its voltage is only  $11.2\text{V} \times 10\text{k}/(33\text{k} + 45\text{k}) = 1.4\text{V}$  which is fine for U3. With a low load current on the project then the pin 2 input of U3 is 0V. Then the pin 3 input is higher than the pin 2 input so its output is high which turns off the LED and it does not limit the project's output current. U3 will be barely warm. If you are using the tiny surface-mount package then it will be obviously warm but not hot.

When P2 connects pin 3 input of U3 to R17 then its voltage is almost 0V which is fine. A load on the project that has a current higher than a few mA will cause the output of U3 to go low which causes 3mA in R20 which turns on the transistor driving the LED. The low at the output of U3 also causes D9 to reduce the voltage to the input pin 3 of U2 which reduces the output voltage of the project so that the output current is reduced. U3 gets a little warmer but not hot and U2 does not get hot unless the driver or output transistor is connected backwards (collector and emitter pins swapped).

You also had the output never less than 15V which might be caused by the driver or output transistor with its collector and emitter pins swapped. Then U2 and the driver transistor will get very hot.

---

**Q:** Is my 30V / 3A transformer the right one to use?

**A:** No, it will overheat. It can supply 30V at 3A which is 90VA, but the rectifier works with the peak voltage that is 42.4V ( $30 \times 1.414$ ) so when the project has an output of 3A then the transformer must supply  $42.4V \times 3A = 127.2VA$ . Use a 28V or 30V transformer rated at 4.3A

---

**Q:** Is it alright to use bridge rectifier MDA980-1 which is rated at 12-30 Amps and 50 volts, or should I stick with the 4 x 1N4148 diodes?

**A:** The MDA980-1 has a max voltage rating of only 50V which is very close to the peak voltage of 42.4V produced by the transformer. The peak voltage might be 44V without a load and power line spikes will be higher. Use a MDA980-2 that is rated at 100V. A 1N4148 is a tiny low current signal diode, not a power rectifier.

---

**Q:** I have a problem.

In the zero position of P1, the voltage at the output is 60 millivolts.

Situation RV1 result is not affected (not regulated).

Help please!!

**A:** Make sure that the output of P1 goes down to 0V.

The max offset voltage of the TLE2141 is only 1.4mV for the inexpensive one and the circuit amplifies it 3 times to only 4.2mV.

RV1 adjusts the output from negative 30mV to positive 30mV so the null should be 0.00V.

Like I said earlier, if the output capacitor C7 is an electrolytic type then it has "dielectric absorption" where it holds a charge even if it is shorted for a while. Use a film capacitor instead and add a resistor across the output to discharge it.

If C7 (the output capacitor) is an electrolytic type then it has "dielectric absorption" where it stores a charge even if it is shorted. Then the output always has a voltage even if the voltage pot is turned down. It also messes up the setting of RV1 that should adjust the output offset voltage about plus and minus 50mV so that it is 0V when the voltage setting pot is turned down.

The capacitor type with the lowest dielectric absorption is a metallized plastic film type. If C7 is changed to a film capacitor (Polyester, polypropylene, mylar) then the dielectric absorption problem will disappear. A 10uF film capacitor is pretty big. Place a 4.7k/0.5W resistor in parallel with it to help it discharge.

---

**Q:** Is there any detailed description of this PSU? I am especially interested about U1 voltage reference. I don't understand how output of U1 gradually increases? What makes potential difference on the U1 plus and minus terminals to force output rise?

**A:** When power is applied, D8 does not have enough voltage to conduct but the opamp has positive feedback from R5 and R6 so it greatly amplifies the noise in the opamp U1 until the output voltage reaches about 10V when the zener diode D8 begins to conduct. When pin 2 rises to +5.6V then the output is 11.2V.

Q4 gets hot only when the load current is high and the voltage at the output is low.

Q1 is normally turned off. It turns on for a moment only when the power to the project is turned off so it shorts the output of U2 to ground to keep the output voltage from rising when the negative -5.6V supply disappears quickly but the positive supply is still discharging C1 slowly.

Measure the voltage at the input pin 3 of U2 and its output pin 6 when the voltage setting pot is turned up then is turned down.

Double-check the pins on Q1, Q2 and Q4.

U2 is the voltage regulator. It drives emitter-followers Q2, Q4 and Q5 to supply enough output current. U2 has a typical open-loop voltage gain of about 200,000 so if the output voltage tries to drop 4V then U2 amplifies the error which produces a drop of only about 0.001V to 0.01V.

The power output transistors operate poorly at high frequencies. C6 and C9 make sure that their phase shift does not cause oscillation at a high frequency. C5 is a high frequency filter for the supply voltage for the output amplifier that helps to prevent oscillations at high frequencies.

C7 makes the output have a low impedance at high frequencies.

Usually a circuit that is powered has a supply bypass capacitor so its supply is a low impedance at high frequencies.

Q2 is the driver transistor and is an emitter-follower. Its base is fed from opamp U2 and its emitter feeds the bases of the output transistor emitter-followers Q4 and Q5. The output is fed back to U2 as negative feedback so the entire amplifier is very accurate and stable.

The output voltage of U2 (and the base voltage of Q2, Q4 and Q5) varies a little when the output current varies so that the output voltage is constant.

---

**Q:** I have a problem with the current limit indicator it was glowing before but not now what should I check?

**A:** The LED lights and current regulation happens when U3 detects the voltage across R7 caused by load current is more than the voltage set at the current regulation pot. 3A in 0.47 ohms causes a voltage of 1.41V. The slider of the current setting pot should go from almost 0V to +1.41V.

---

**Q:** I finished the build of this power supply, but output voltage is very low (0-2v).

**A:** The output voltage of U1 should be +11.2V.

The slider of the voltage setting pot should go from 0V to +11.2V.

U2 and the output transistors form an amplifier with a voltage gain of  $(27k+56k)/27k = 3.074$  so the 11.2V input to U2 creates 34.4V at the output if the unregulated supply voltage is high enough.

Check the datasheets for the pins on the driver and output transistors.

Check that R11 is 27k and R12 is 56k.

---

**Q:** The current pot turns on the LED shortly after I increase the current regulation pot?

**A:** The current regulation pot sets the max amount of current the output of this power supply can provide.

RV3 calibrates the max current to be 3.0A.

At zero rotation the warning LED should not light if there is no load.

At half-way rotation the warning LED should light and the output voltage should drop only when the load current tries to be 1.5A or more.

At maximum rotation the warning LED should light and the output voltage should drop only when the current tries to be 3A or more.

---

**Q:** My U1 and U3 op amps are getting hot (U1 a little bit more) is that normal without any load on power supply, only the voltmeter at the output.

**A:** I am assuming that your unregulated supply is +40V for the 5A PSU.

If U1 is an MC34071 then it has an idle current of 2.8mA max which causes heating of  $40V \times 2.8mA = 112mW$ . U1 has an output of 11.2V and an output current of 5.6mA so it heats with an additional  $(40V - 11.2V) \times 5.6mA = 161.3mW$ . Then the total heating is 273.3mW max which will make it warm, not hot.

A tiny little surface-mount package might get hot.

If the circuit is made on a breadboard then the opamp will probably oscillate and get hot.

If U1 is a TLE2141 then it has an idle current of 4.4mA max. Its total heating is 337.3mW max which will make it warm, not hot.

A load on the power supply will reduce the unregulated supply voltage a little which will make opamps U1 and U3 a little cooler. U2 will get a little warmer.

---

**Q:** When I'm adjusting RV2 to limit the output to 30 volts I'm getting only 1.1 volt when I'm bringing the potentiometer to 0.

**A:** RV2 is adjusted for an output voltage of 0.0V when the voltage pot P1 is set to zero. RV2 is supposed to adjust only about +/- 0.05V to cancel the amplified input offset voltage of U2. C7 will hold a voltage if there is no load.

The voltage-setting pot P1 adjusts the output voltage from 0.0V to 30.0V.

The current regulating circuit adjusts the current by using U3 and D9 to reduce the voltage at the input of U2, exactly the same as the voltage-setting pot.

U2, Q2 and the output transistors are simply an amplifier of the 0V-11.2V from the voltage adjust pot with a gain of 1.93 to 6.6. The gain is adjusted with RV2 and with the voltage pot P1 at max RV2 is adjusted for an output of 30.0V.

The current in the load is also in R7 which is 0.47 ohms for a max of 3A output. The voltage across R7 is caused by the load current and is compared by U3 with the voltage set by the current-setting pot P2. RV3 adjusts the sensitivity of the current-setting pot P2.

With no load current then R7 has no voltage drop and the current-setting pot feeds a small positive voltage to the (+) input of U3 so its output goes high and it does not limit the current.

RV1 nulls the input offset voltage of U2 and is adjusted for an output of 0.0V when the voltage setting pot is set to minimum. But C7 is an electrolytic capacitor that stores a charge (electrolyte absorption) which causes a positive output voltage for a long time. If C7 is a film capacitor then adjusting for 0.0V is easier.

---

**Q:** How much should be the value of resistor that I should put at output so as to bring the voltage to zero?

**A:** Maybe a 3.3k 0.5W resistor should be added to the output to discharge C7. (Connect it in parallel with C7).

---

**Q:** I can't seem to set the max current limit by means of RV3. I have shorted the output though my meter, and no matter the adjustment of RV3 the current rises over the 4amp mark when I quickly increase and decrease the current POT setting.

**A:** Since your current regulator does not work then U3 or D9 are not working. Maybe D9 is open or it is disconnected.

Maybe you messed up the connections to the current-setting pot or RV3. A common mistake is to connect the pot wiper to the wrong point on PCB.

RV3 is in series with R18 and the current-setting pot so it sets the max current before the current-regulation reduces the output voltage. The max resistance of RV3 is 100k and it is in series with R18 which is 33k so their total is 133k ohms. The original project used a total of only 56k so its max current was about 4.1A. With RV3 at 100k plus 33k in series for R18 your max current should be 2.06A.

If your RV3 is set at halfway to 50k then in series with R18 the total is 88k then the max current should be 3.35A. The current-setting pot should be 10k ohms. R17 should be 68 ohms. R7 should be 0.47 ohms.

Test the voltage regulation at a lower voltage. The voltage should not drop more than about 0.02V when a load of 3A is connected.

---

**Q:** My power supply isn't supplying any power. Would the op amps be the problem? If so how can these be tested?

**A:** U2, Q2 and Q4 are an amplifier with a voltage gain determined by the values of R11 and R12. R11 is 27k and R12 is 56k so the voltage gain is  $1 + (56k/27k) = 3.074$ . The trimpot reduces the gain to be low enough so that the max output voltage is 30.0V when the voltage pot is set to max and has 11.2V from U1.

D9 is reversed-biased so when cathode is high it does nothing.

U1 has its voltage gain set to 2 times by R5 and R6. So the 5.6V zener diode D8 has its voltage doubled to +11.2V at the output of U1. Gain is  $(10k+10k)/10k = 2$ .

Measure the output of U1 and it should always be close to 11.2V. It feeds the voltage-adjust pot P1. Check that D8 is a 5.6V low current (5mA spec.) zener diode and check the values of R4, R5 and R6. Disconnect the output transistors, strap the gap to R12. Power on to verify the circuit works up to U2 pin 6.

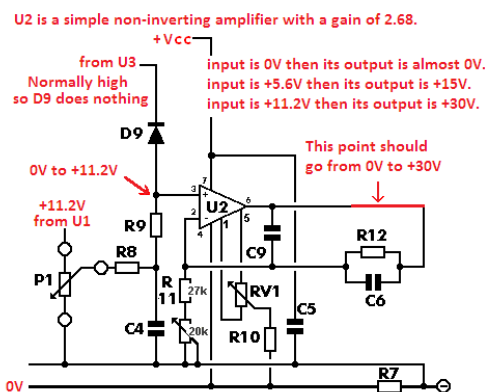
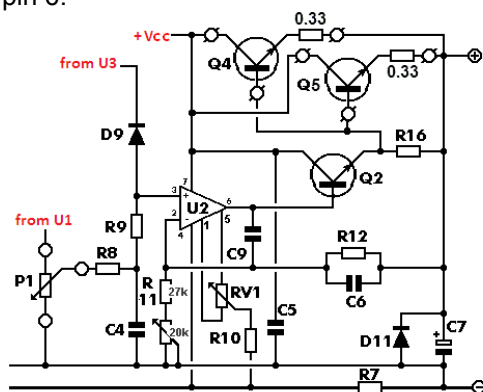

**Q:** For what purpose are the 3 trimmings? For what adjustments? And is there a way for fine adjustment of the Voltage and Current.

**A:** The trimpot RV1, between pin 1 and pin 5 of U2, nulls its input offset voltage. With the voltage set to 0V then the trimpot is adjusted for exactly 0.0V.

With the output voltage set to maximum then the voltage calibration trimpot is set to 30.0V.

With a 3A load and the current regulation set to maximum the current regulation calibration trimpot is set to 3.0A

---

**Q:** How do you measure maximum current? Just connect an ammeter to output? During that the voltage out be set to maximum?

**A:** An ammeter has resistance so when it is connected in series with a load then it reduces the voltage to the load a little. Then the current in the load is reduced a little. Connect an accurate low value power resistor to the output then measure the voltage across it and use Ohm's Law to calculate the max current and adjust the current calibration trimpot RV3 for 3.0A.

---

**Q:** Hello, I still don't get how and when to set up MIN, MAX voltage value and MAX current value. For example, I have a water heater as a load, which has a rating of 220V, 700W and I measured its resistance; it is 71 Ohms. What should be the readings of voltmeter and ammeter, when this load is connected to the power supply output and voltage and current pots are set to maximum? Would they show 30V and 3A?

**A:** Ohm's Law says that the current in 71 ohms when it has 30V across it is  $30V/71\text{ohms} = 0.4225A$ . For a current of 3A then the 71ohms needs  $3A \times 71\text{ohms} = 213V$  across it. If you want 30V and 3A then the load must be  $30V/3A = 10\text{ohms}$ .

---

**Q:** The Voltage regulator is working perfect. The current regulator also work, but when the potentiometer is nearly at the beginning (few mA's) the current limit LED lit and the voltage goes to almost 0V (with 15-16V regulated for example). So is there something wrong with the current regulator or is that normal?

**A:** Your opamp U3 current regulator has a high input offset voltage. Null it with a trimpot and resistor between pin 1 and pin 5 of the opamp. (like at U2 output voltage amplifier) or increase the value of R17. R17 on the schematic is 68 ohms. If its value is increased a little then the current regulator will stay off without a load.

---

**Q:** BD139 keeps popping when I load (short) the supply (with C1 now connected). While trying to adjust RV3 to set the max current, the DB139 pops. What I do is, adjust the current pot down to min, slowly adjust it up to about 2Amp, when I get there (only shorting for about 1 second), I adjust the RV3 down, (adjusting both in steps on after the other if you know what I mean?) until I have adjusted the pot to max, but when I have adjusted the current pot to max and I short the output, it pops the BD139, within 0.5 seconds. Measurements... U2 out = 80mV; PSU output Voltage is 2.2V unloaded, 300mV with 10K resistor across output. (electrolytic cap problem?)

**A:** The TLE2141 opamp has inputs that work at 0V and has an output that goes almost to 0V. When the voltage pot is at minimum then the input to U2 is 0V. The BD139 and the two 2N3055 transistors are simple emitter-followers so the output of the TLE2141 is about +1.4V when the output of the project is 0V. The opamp and transistors are an amplifier with a voltage gain of 2.68. The TLE2141C has a max input offset voltage of about 1.5mV when warm so the max output before nulling the offset voltage is only 4mV.

So there is your problem. The output of U2 is the base voltage of Q2 which is only 0.08V. The emitter is much less because Q2 is an emitter-follower so should be at 0V (measure it and report here). Q4 and Q5 are also emitter-followers with a base voltage of 0V so their emitters at the output should also be 0V (unless they or C7 is leaking current).

The datasheet for a 2N3055 transistor shows that its maximum collector to emitter leakage current is 0.7mA when it has a Vce of 30V, it is at 25 °C, so, two will have 1.4mA, then, when there is no output load current the output voltage rises. Try two new 2N3055 transistors to see if they are much better. Also replace D11 that might be leaking current.

**Q:** OK, I replaced D11 and 2 new 2N3055's, output voltage now is 0.22V with a 10K resistor across outputs.

**A:** The output now is only 0.22V so simply live with it. Maybe the 2.0V was caused by leakage in the 2N3055 transistors or in D19.

Somebody else tried a 10uF **film** capacitor for C7 which fixed his problem with the output voltage not going down to 0V.

**Q:** Just not winning, I'm happy with the voltage reg side, but I just popped another BD139 while calibrating the max current (by shorting through a multimeter), I had voltage set to about 12V-14V, the RV3 set to min current, I shorted the output (for 1 second intervals) and slowly worked the current Pot up until I reached the max position, which was about 1.4 amps or something, I then started increasing RV 3 to increase the max current limit (1/2 turn at a time so to not over shoot the 2.5 amp limit I want), but at about 1.7 amps, Q2 popped.

**A:** If the shorted output current is only 1.7A then each 2N3055 transistor has 0.85A. Their **minimum** current gain is 54 at such a low current so their base current which is also the collector or emitter current of the BD139 is only  $1.7A/54 = 31.5\text{mA}$ . The BD139 has 34V across it so it dissipates only  $31.5\text{mA} \times 34V = 1.1W$ . If the 2N3055 transistors have typical current gain then the power in the

BD139 transistor is only 0.46W.

The BD139 is rated to withstand a  $V_{ce}$  of 80V to 100V, a current of 1.5A continuously and a power continuously when fairly hot (its case is 70 °C) of 8W.

Maybe you have counterfeit transistors with low gain or poor thermal mounting inside.

Maybe the BD139 takes the entire load current because maybe the collectors of the 2N3055 transistors are not powered? Then it will dissipate  $34V \times 1.7A = 57.8W$  which blows it up. The BD139 will take the entire load if the base and emitter of one 2N3055 is shorted together or if both 2N3055 transistors do not have their collectors (their metal cases) connected to +35V.

**Q:** I feel like an idiot now, you have hit the nail on the head, only one of the 2N3055 cases were connected to the +35V. Tested it to 3A and all is OK.

---

**Q:** When Current pot set to min, current limit LED comes on. LED has slight glow all the time, even when not in "CC mode".

**A:** The LED is driven from Q3. When not regulating current the output of U3 is high enough to turn off Q3. Measure and report the voltage at the output of U3 and at the base and emitter of Q3.

Maybe you have R19 and R20 swapped. Maybe Q3 is leaky. Maybe the emitter and collector of Q3 are swapped.

**Q:** Ok, replaced Q3, LED problem sorted, thank you.

---

**Q:** No-load, current is not regulated, only voltage. When I connect the load, lights LED, can regulate the current, but does not regulate voltage.

**A:** It cannot regulate the voltage when it is regulating the current.

It regulates the current by reducing the output voltage until the current is at the same low value as the setting of the current-regulation pot. For example when you short the output to 0V then the output voltage goes to 0V and the current is regulated to the setting of the current-regulation pot.

If you turn up the current-regulation pot so that the actual output current is less than the setting of the pot then the output will have voltage regulation.

**Q:** But why can't I regulate the voltage when connecting the load, only the current. My test load is a car 60 watt lamp.

**A:** You need to turn up the current-setting pot so that the load current is less than its setting. Then the red warning light turns off and you can vary the voltage regulation voltage with the voltage-setting pot. The lamp draws 5A at 12V when hot and it draws maybe 50A when cold.

The moment that you connect it then it will try to draw 50A but the current-regulation will limit its current to only 3A by limiting or reducing the voltage.

If you turn the current-setting to maximum and the voltage to zero, connect the light bulb then slowly turn up the voltage it should work up to maybe 10V at 3A.

Your video shows that the warning LED lights when there is no load and the current-setting pot is turned down which is wrong. It is due to an input offset voltage of U3. Increase the value of R17 (it is now 33 ohms) to maybe 47 ohms or 68 ohms until the LED does not light when the current-setting pot is at minimum.

p.s. it would be better to use a heater element for instance, as a load.

**Q:** Let me inform you that I have changed the value of R17 from 33 Ohm to 47 Ohm, and now the warning LED of the current limiter does not light when there is no load, thank you Audioguru.

---

**Q:** What about if you want to charge a battery, let's say for example, 12 Volts and 2.5 amps. When the battery draws 5 amps...and you want to limit the current for a better charging...when the current limiter is activated you can't regulate the voltage to 12 volts....

**A:** Set the voltage to 13.8V - 14.4V and set the current to 2.5A if you want. The current regulation will reduce the voltage to whatever the battery needs when it draws 2.5A. The voltage will slowly rise as the battery charges and the current will stay at 2.5A until the battery becomes near fully charged.

---

**Q:** Can anyone explain about adjusting the trimpots and final testing procedures? Also I notice that the 10W 0.47Ohm resistor gets very hot (about 60C). Is this normal?

**A:** The dissipation in the 0.47 ohm resistor is  $I^2 R$ , so with a current of 3A it dissipates  $3 \times 3 \times 0.47 = 4.23W$  which makes a 10W resistor very warm. 4A creates a dissipation of 7.52W which is a lot of heat in the small space of a 10W resistor.

**RV3** is to set the maximum current to 3 [or 5 for 5A PSU]; (**one** way to set: short the PSU, adjust P2 (amp knob) to max, adjust the RV3 to desired maximum current, be quick, the transistor will get HOT).

**RV2** is to set the maximum voltage to 30v (how to set: in open circuit adjust the P1 (volts) to max, adjust the RV2 to be 30v at the terminals of the PSU).

**RV1** is to set the ZERO voltage (how to set: in open circuit adjust the P1 (volts) to min, adjust the RV1 to be 0v at the O/P terminals of the PSU).

The current sense resistor is 0.47 ohms for the 3A power supply and is 0.27 ohms for the 5A power supply.  $3A \times 0.47$  ohms produces 1.41V and  $5A \times 0.27$  ohms produces 1.35V.

Adjust RV3 so that the slider of the current pot is 1.41V at a load of 3A or is 1.35V with a load of 5A (at U3 pin 3). Then any more current will cause opamp U3 to reduce the output voltage which will regulate the current.

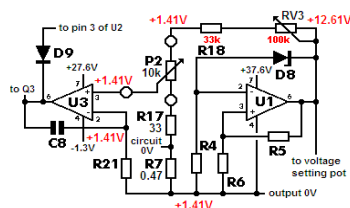

P2 is set to maximum for a current of 3A.  
3A in R7 creates a voltage of 1.41V across it.  
P2 is 10k ohms so its 1.4V across it has a current of 0.14mA.  
RV3 is  $(12.61V - 1.4V)/0.14mA = 33k = 47.1k$  ohms.

If the current tries to exceed 3A then the voltage at U2 gets reduced.

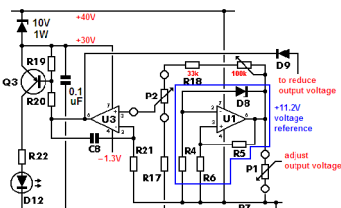

U3 controls the current regulation. P2 sets the current and P1 sets the voltage.  
With no load then pin 2 of U3 is at 0V. Pin 3 has a small positive voltage from P2. Then the output of U3 is as high as it can go which prevents current regulation and prevents Q3 from lighting the LED.

When the load current exceeds the setting of P2 then pin 2 of U3 has a voltage that is higher than pin 3 so the output of U3 goes low which reduces the output voltage with D9 and turns on Q3 which lights the LED.

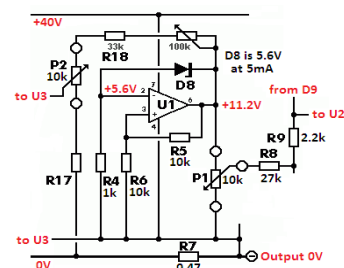

U1 circuit is a simple voltage reference. It uses an opamp U1 to amplify a 5.6V zener diode by a factor of 2, due to the ratio of R5 and R6, to 11.2V

**Q:** The power supply worked great right up until I hooked up my 18v Dewalt drill test motor, now I get 34 volts through the output, nothing less.

**A:** Maybe the current regulation is not working and you overloaded this power supply circuit. Then the output transistors and/or driver transistor and/or opamp are shorted.

**Q:** I've disconnected the driver transistor and output transistors and still get 34 volts at pin 6.

That is normal because you disconnected the negative feedback from the output to pin 2 so the voltage on pin 2 is much too low which causes the output pin 6 to go as high as it can.

**A:** IC1 is an amplifier with a voltage gain of 2.0 and it amplifies the voltage of the 5.6V zener diode D8 so the output of U2 should be 11.2V.

U2, the driver transistor and the output transistors have a voltage gain of  $R12/R11$  (plus one) that is changed a little by the voltage calibration pot RV2. They amplify the 0V to 11.2V from the voltage setting pot up to 30.0V so the voltage gain should be 2.67857 times. (The voltage reference from U1 is 11.2V and the maximum output from the project is 30.0V. Then the output amplifier must have a gain of  $30V/11.2V = 2.679$  times).

*[/quote] I get 28.2V at the output of U3. [unquote]*

When not regulating the current, the output of U3 should be higher than 11.2V, 28.2V is fine. R11 and R12 are a voltage divider that divide the output voltage by about 2.68 times to feed negative feedback to pin 2. When pin 3 is +11.2V then the output of the project will be +30V and pin 2 will also be +11.2V.

Measure the output transistors and driver transistor with an ohm meter to see if they are shorted. If they are not shorted then connect them in the circuit and with the voltage setting pot at zero tell us the voltages at pin 2, pin 3 and pin 6 of the opamp and the voltage at the output of the project.

**Q:** Right again it was the BD139 now I get my variable back and I checked my amps with just a LED and I can control my amps. Thanks guys for all your help.

**Q:** Why do I need to use 3 x 2N3055's in parallel to get the 5 Amps?

**A:** In this 5A project, the power supply to the 2N3055 output transistors is 40V and there is a loss of 0.55V in their emitter resistors and a loss of 1.35V in the current-sensing resistor. Then when the output current is set to 5A and shorted, the output transistors must dissipate a total of  $5A \times 38.1V = 190.5W$ . One output transistor will be much too hot and two will try to dissipate 95.3W each which would be impossible to cool. So three output transistors are used and each dissipates up to 63.5W which is a lot of heat to remove but is possible.

**Q:** I will use the 5A (Rev3) version of this project, so I'll use three transistor and transformer 30VAC / 210VA.

I need this calculation for calculate heatsink thermal resistance for three paralleled 2N3055.

Is this calculation is correct or not?

$Pd = 5A \times (40V - 0.55V - 1.35V) = 190.5W$

I got 0.55 from total voltage drop of three 0.33ohm paralleled resistors ( $0.11 \times 5$ ), 1.35 is voltage drop on shunt resistance R7 ( $0.27ohm \times 5A$ )

**A:** Your calculations are correct. When the output is set to 5A and is shorted then each 2N3055 output transistor must dissipate  $(190.5W)/3 = 63.5W$ .

Thermal compound adds about 0.2 °C per Watt, the heatsink is, say, 0.5 °C/W, so total thermal



resistance is 0.7 °C per Watt.

Maybe the ambient temperature is 30 °C. Then 190.5W causes the chip of each transistor to become  $(190.5 \times 0.7) + 30 = 163.4$  °C which is extremely hot but not too hot (200 °C is the maximum for a 2N3055).

A huge heatsink cannot provide enough cooling so a high velocity fan must be added.

**Q:** I am not sure what type of heat sink I should pick for Q2 (BD139). It only says "on a pretty big heat sink" in the parts list, which is a kind of vague assertion.

**A:** If three 2N3055 output transistors share the 5A of current then each has 1.7A and its minimum current gain is 40. Then the current in the BD139 is a max of 125mA. Its max voltage is 36.2V so its max power dissipation is  $125\text{mA} \times 36.2\text{V} = 4.5\text{W}$ .

The max allowed chip temperature of a BD139 is 150 °C but 130 °C is safer. Your ambient temp might be 30 °C. The thermal resistance from chip to case is 10 °C/W and for thermal grease it is about 0.3 °C/W.

Using the formula to calculate the thermal resistance of the heatsink.

**since:**

$$\Theta_{JA} = \Theta_{JC} + \Theta_{CS} + \Theta_{SA} = (T_{JMAX} - T_A) / P$$

**then:**

$$\Theta_{SA} = [(T_{JMAX} - T_A) / P] - (\Theta_{JC} + \Theta_{CS})$$

where:

Tj = junction temperature, °C

Pd = power dissipation, W

Θjc = junction to case thermal resistance, °C/W

Θcs = case to heatsink thermal resistance, °C/W

Θsa = heatsink to ambient thermal resistance, °C/W

Θja = junction to ambient thermal resistance, °C/W

Ta = ambient temperature, °C

Specified in Recommended Operating Conditions

Power dissipated by the device

Specified in the data sheet

Insulator thermal resistance

Specified by heatsink manufacturer

Specified in the data sheet

Temperature of the local ambient air near device

where: case = the device body

So the required specification of the heatsink for a BD139 in this circuit is:

$$[(130^\circ\text{C} - 30^\circ\text{C}) / 4.5\text{W}] - (10^\circ\text{C} + 0.3^\circ\text{C}) = 11.9^\circ\text{C/W}$$

**Q:** Hi, is there any place in the circuit of this project where I could be add on an additional LED diode, which should be on all the time, when the power supply is on?

**A:** The rectified and filtered +40V can light an LED if it has a current-limiting resistor.

An LED is 1.8V to 3.8V depending on its colour. If the LED is a 1.8V red one then for 15mA the resistor is  $(40\text{V} - 1.8\text{V}) / 15\text{mA} = 2547$  ohms. Use 2.7k. Its power is a little more than 1/2W so use a 1W or 2W resistor.

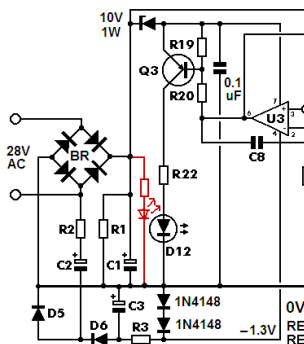

**Q:** Hi, I am facing the problem Please help me out. At the output of U1 I get 11.8V and at the output of U2 I get 34V. But at pin 2 and pin 3 of U3 is 14.2V and 15V respectively. R3 gets heated up and I replaced three times already. Across the load resistor (20W, 10K) I get 41V and the same voltage is across the output of bridge and output voltage is not varying by 20K pot.

**A:** You have many serious problems, probably caused by wiring errors.

1). The output of U1 should be +11.2V but yours is 11.8V which is only 5% high so it is fine.

- 2). The output of U2 should go from 0V to +33V when the voltage setting pot is adjusted. It might always be +34V if you have the pins of the driver transistor or the output transistors connected backwards. Look at the datasheets to see the pins.
- 3). Pin 2 of U3 has an extremely low current and is connected through R21 which is 10k to the output ground so how can it be +14.2V? Maybe your R7 is not 0.47 ohms?
- 4). Pin 3 of U3 connects to the current setting pot between 0V and about +2V so how can it be +15V?
- 5). R3 has only the few mA of U3 in it so how can it get hot?
- 6). Your output is shorted to the output of the bridge rectifier.

**Q:** I have checked my circuit again and resolved the wiring errors. The voltage across two 1N4148 diodes connected in series is -11.2V not -1.3V. Why?

Voltage across R3=14V that's why it gets burnt. Why?

**A:** The two diodes are supposed to conduct a small current which clamps the voltage to -1.3V.

Maybe your diodes are connected backwards or maybe they are burned out.

R3 is fed a small current from rectifier D6 which has its current limited by R2. The other end of R3 is fed to the voltage-limiting diodes and the negative power supply pin 4 of U3 that draws only a couple of mA.

The current in R3 is supposed to be low.

**Q:** Why when the current limiter is enabled the voltage drops??? I know that it has to do with ohms law but I need more specific details... I mean why does the voltage drop instead of staying steady ... For example; we have a device that needs 12v 3.2A to operate. If we set the voltage pot to 12V and the current pot to 2.5A then we will notice that when the current reaches 2.5A the voltage will start falling (don't know how much). Why is that happening instead of preserving the voltage steady to 12V and the current to 2.5Amps

**A:** You want 12V at 2.5A. Then Ohm's Law says the load is  $12V/2.5A = 4.8$  ohms.

You set the voltage to 12V and you set the current regulator to 2.5A and load it with only 2 ohms.

Then Ohm's Law says the voltage MUST be  $2.5A \times 2 \text{ ohms} = 5V$  as shown with Ohm's Law again, so the output voltage is reduced.

If the voltage stayed at 12V then the current in 2 ohms would try to be  $12V/2 \text{ ohms} = 6A$  which is impossible in this supply that has a maximum current of 3A.

**Q:** My constant current light is on when I have the pot turned all the way counter clockwise.

I traced the problem to my combo LED (amp and volt) meter which put a small load on the output.

So the sense circuit is putting a small voltage on U3 pin 2, enough to turn-on Q3. Verified it by taking pin 2 to ground which turned off the LED.

Question: By changing R21 (10k) resistor, can I off-set the small load created by the LED panel??

OR, do you have any other ways to correct my problem?

**A:** R21 simply allows C8 to slow down the switching of U3.

Instead, increase the value of R17 so that the LED does not turn on when there is a small output load.

**Q:** After more testing, I was able to turn-off the constant current LED by powering the LED display with 4 AA (6volts) batteries.

I built a separate supply for the led display, tapped off the transformer secondary, somehow there's some interaction. It seems like you have better results if you totally isolate these cheap \$6.00 combo import meters from your circuit.