

8 CHANNEL LPT AC LAMP CONTROLLER

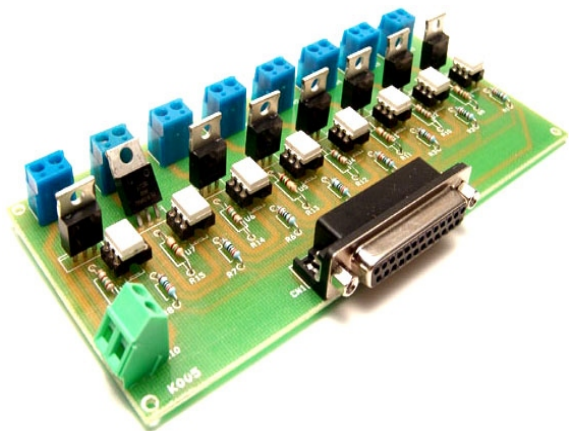

SUPPLY VOLTAGE	12V DC
CURRENT	260 mAmp all Relay working
CHANNEL	8
RELAY LOAD	2AMPS AT 24V DC

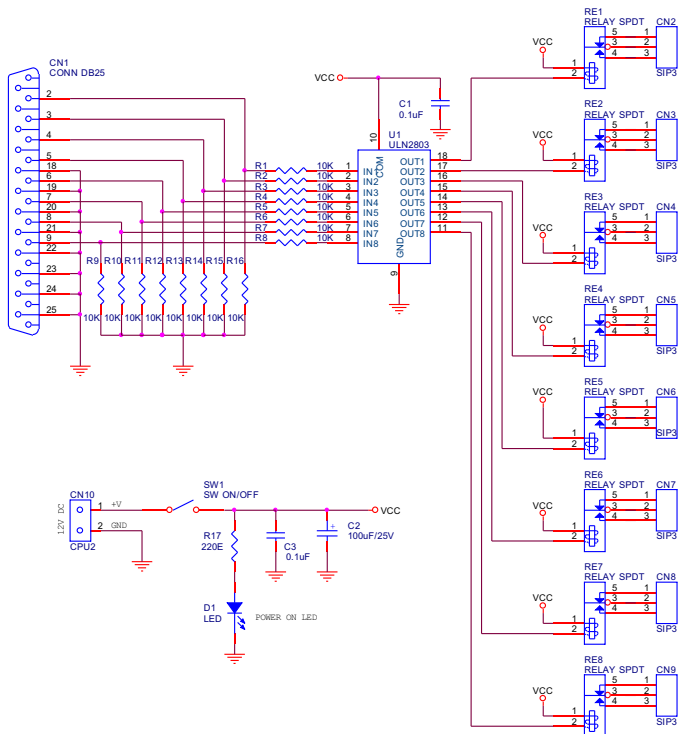

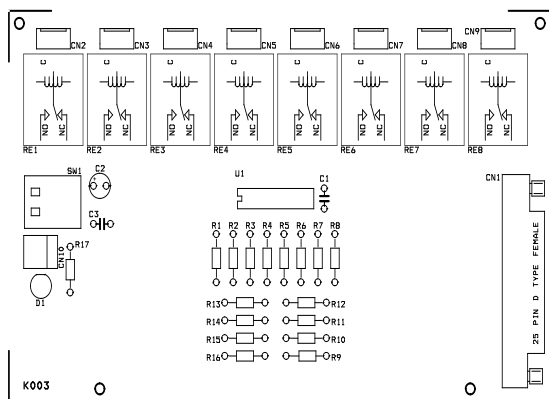
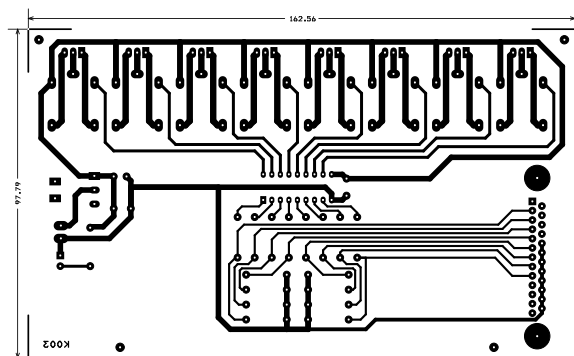

BILL OF MATERIAL

COMPONENTS			
SR	QNTY	DISC	VALUE
1	1	CN1	CONN DB25
2	8	CN2 TO CN10	SIP3
3	1	CN7	CPU2
4	2	C1,C2	0.1uF
5	1	C3	100uF/25V
6	1	D1	LED
7	8	RE1 RE8	RELAY SPDT
8	16	R1 TO R16	10K
9	1	R17	220E
10	1	SW1	ON/OFF SWITCH
11	1	U1	ULN2803