

DC Power Supply For Brush-less DC Servo Motor Drivers

Although the power supply design is specific to the Brushless Servo Drivers mainly for IPM Modules, the concepts and circuit design may be used for any power supply required high voltage output up to 400V DC and 5 Amps. The power supply is as unregulated design with an option to allow connection to either 120V or 230V mains also can work with lower voltage for audio amplifiers by increasing capacitor value. The design uses fully integrated bridge rectifier, and multiple bus capacitors for low ripple, noise suppression, and provides high current reservoirs. Additionally supply dc supply line have bleeder resistor R2 and R3 to drain the large reservoir capacitors PCB mounted fuse holder provided for short circuit and over current protections, low ohm NTC used for inrush current at power start up, C1, C12, TX protects against turn on/off spikes and EMI noise reduction. This power supply can be used to drive Tesla Coils, Induction heaters, DC Motor drivers, Brushless DC motor driver.

Note: Two BOM provided for supply up to 120V AC and BOM 2 for supply input up to 230V AC

Features

- AC Supply input up to 120V AC
- Maximum DC Output 400V DC and 5Amps.
- 230V AC Input possible with few components value alteration
- DC Supply Output will depend on input supply
- Fuse for Short circuit and over current protection
- Fuse as per your application requirement Maximum 5Amps Fuse
- NTC provided for inrush current
- DC Bus has bleeding resistor



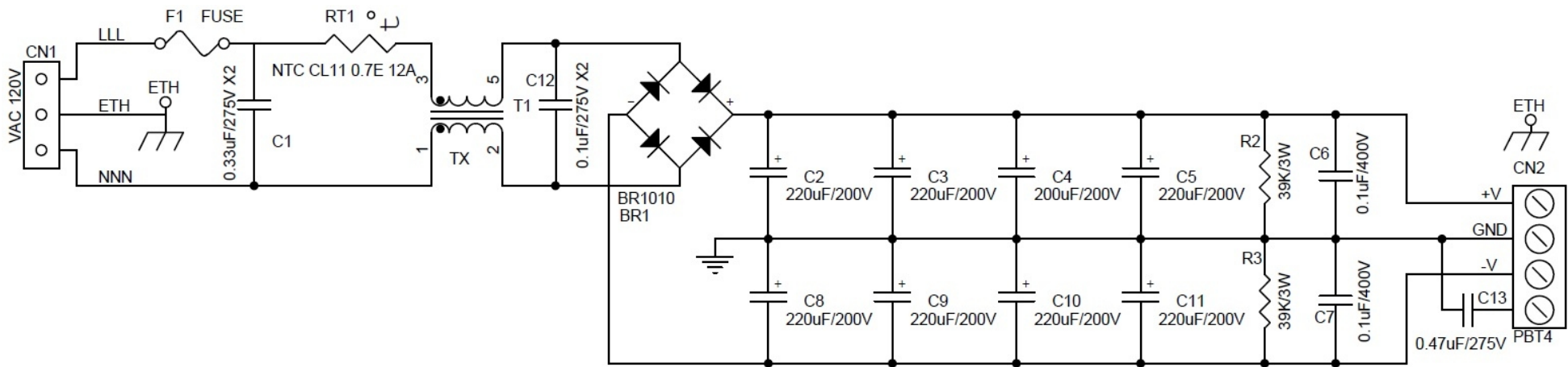

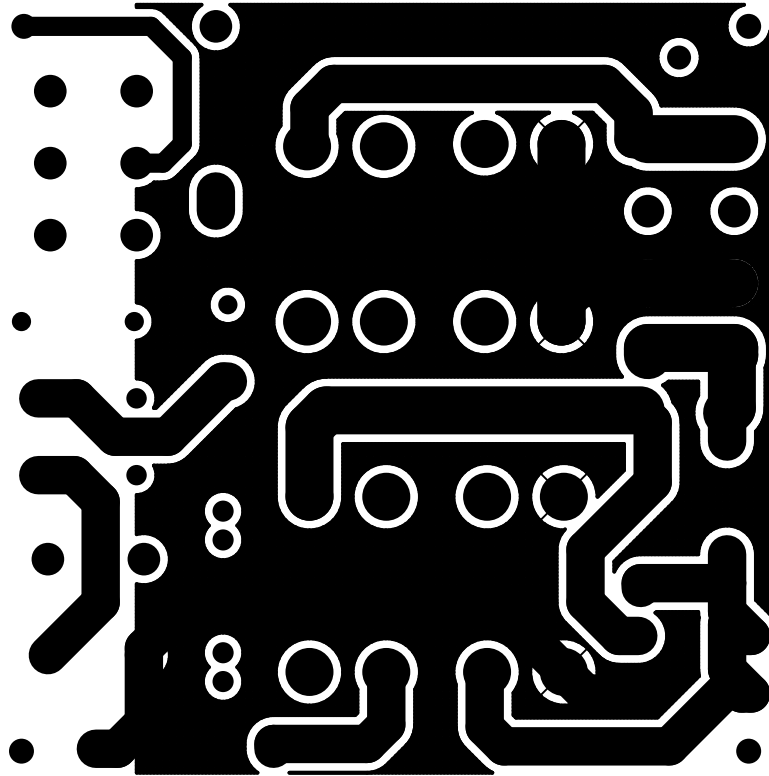

BOTTOM LAYER

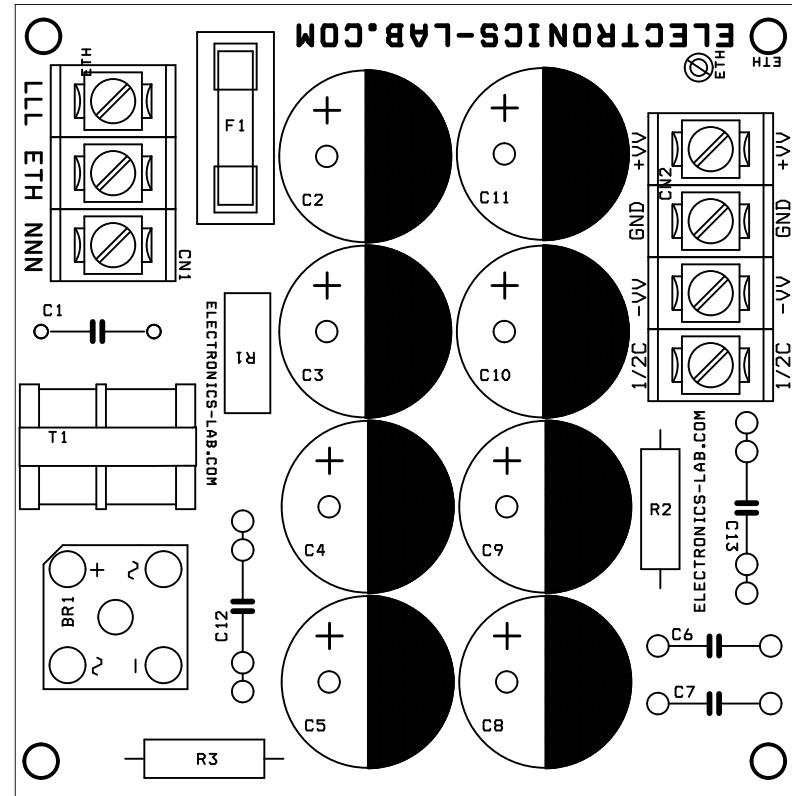

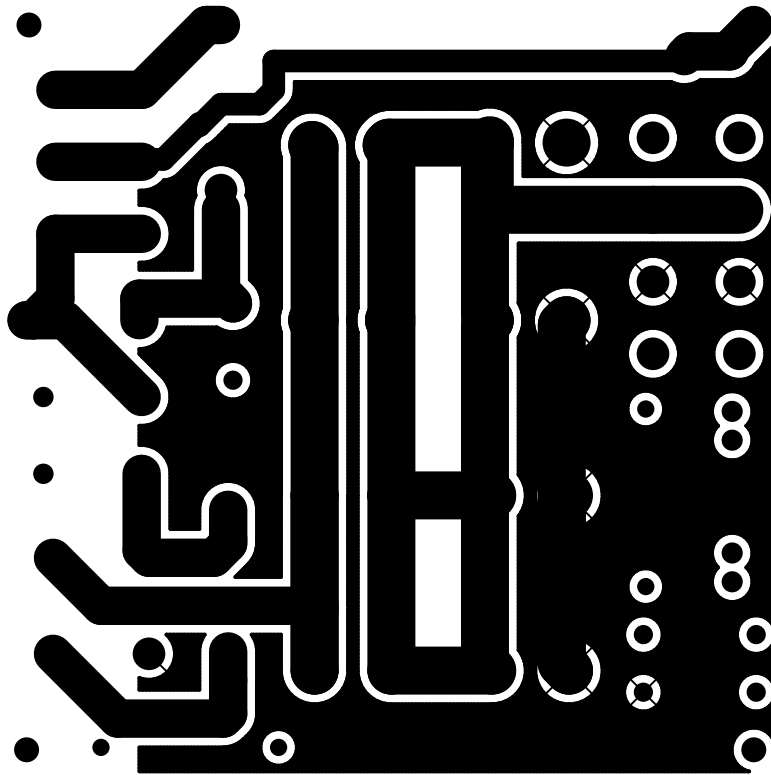

TOP LAYER

BOM SUPPLY UPTO 120V AC INPUT			
SR.	QNTY.	REF.	DESC.
1	1	BR1	BR1010 BRIDGE RECTIFIER10AMP
2	1	CN1	3 PIN SCREW TERMINAL
3	1	CN2	4 PIN SCREW TERMINAL
4	1	C1	0.33uF/275V X2
5	8	C2,C3,C4,C5,C8,C9,C10,C11	220uF/200V
6	2	C6,C7	0.1uF/400V
7	1	C12	0.1uF/275V X2
8	1	C13	OMIT
9	1	F1	FUSE HOLDER
10	1	RT1	NTC CL11 0.7OHM 12A
11	2	R2,R3	39K/3W
12	1	T1 EMI TRANSFORMER	SUMIDA LF2020NP-222

BOM SUPPLY UPTO 230V AC INPUT			
SR.	QNTY.	REF.	DESC.
1	1	BR1	BR1010 BRIDGE RECTIFIER10AMP
2	1	CN1	3 PIN SCREW TERMINAL
3	1	CN2	4 PIN SCREW TERMINAL
4	1	C1	0.33uF/275V X2
5	8	C2,C3,C4,C5,C8,C9,C10,C11	220uF/250V
6	2	C6,C7	0.1uF/400V
7	1	C12	0.1uF/275V X2
8	1	C13	OMIT
9	1	F1	FUSE HOLDER
10	1	RT1	NTC CL11 0.7OHM 12A
11	2	R2,R3	100K/3W
12	1	T1- EMI FILTER	SUMIDA LF2020NP-222