

AC-N IN = AC 110V OR 230V NEUTRAL N-LD1 = LOAD 1 NEUTRAL CONNECTION
 AC-L IN = AC 110V OR 230V LIVE L-LD1 = LOAD 1 LIVE CONNECTION

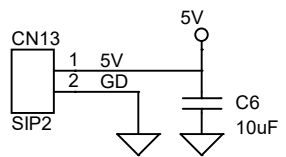
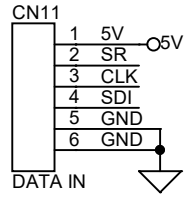
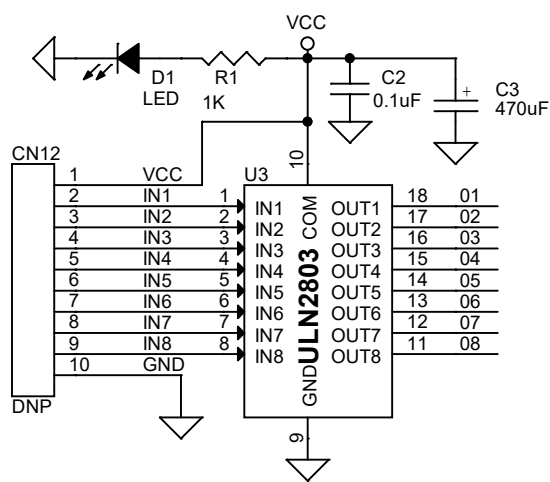
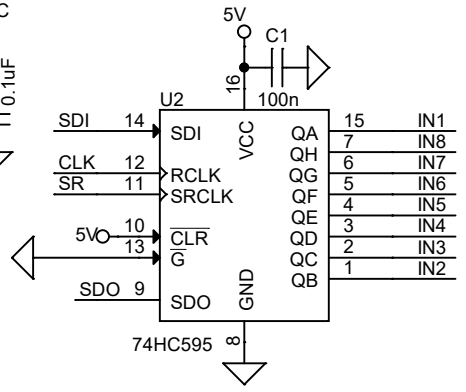
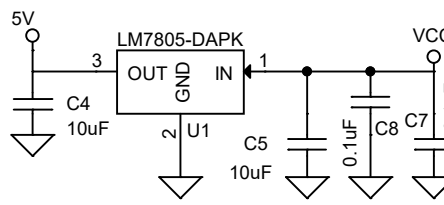
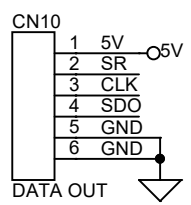
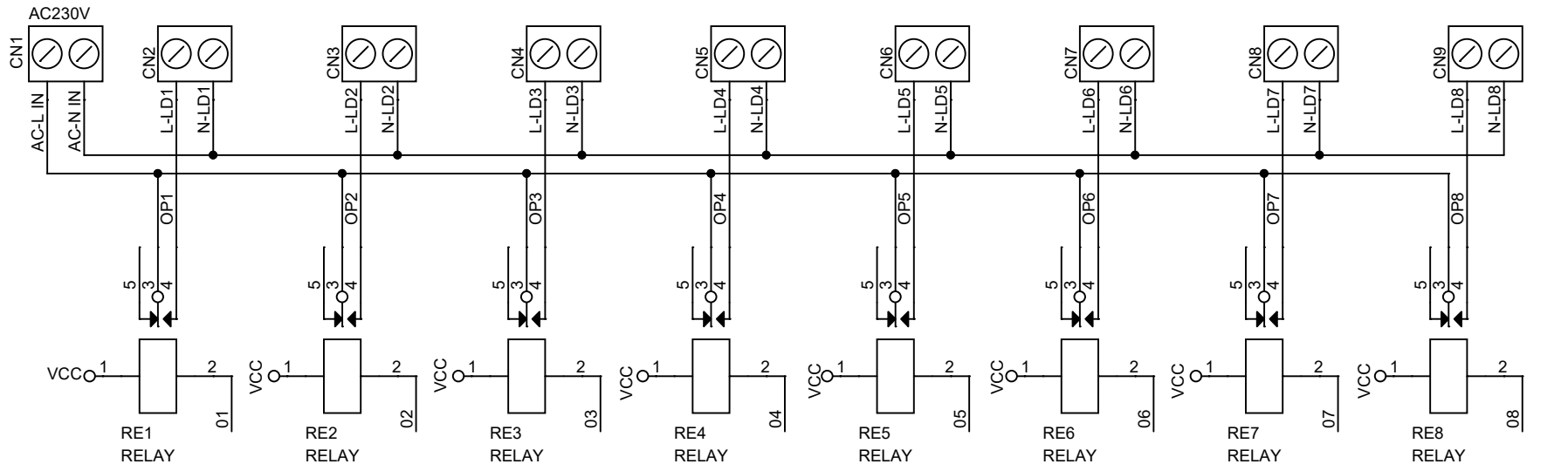

OP1 = SEGMENT A, OP2=SEGMENT B, OP3 SEGMENT =C, OP4 = SEGMENT D, OP5= SEGMENT E, OP6 = SEGMENT F, OP7 = SEGMENT G, OP8 = SEGMENT DP