

THE  
**electronics-lab**  
.com  
from ideas to  
**boards**

[electronics-lab - Projects](#) | [Embedded News](#) | [Online Community](#) | [e-Shop](#)

Open Source Hardware Electronics Projects

[electronics-lab.com/projects](https://electronics-lab.com/projects)

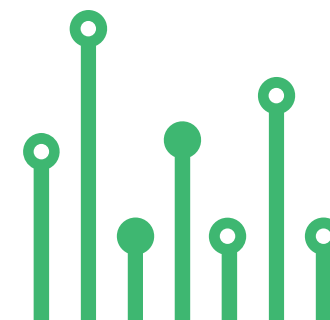



# Overcurrent / Over-discharge Protector for Lead Acid Batteries



SKU: EL130725

# Overcurrent / Over-discharge Protector for Lead Acid Batteries



The project described here protects and monitors a Lead-Acid battery against too-low battery voltage and over-current conditions. The circuit consists of MAX4373 current-sense amplifier with internal dual comparators and P-channel MOSFET in series with the battery and its load. It works as a normally closed switch which can be opened if the current-sense amplifier and comparators detect either a high load current OR a low battery voltage. When over current condition occurs, the comparator latches the output and can be reset by onboard push switch SW1.



**Note 1:** The current sense Resistors R1, R3, R4, R7 are connected in parallel. Each resistor has 1W power rating, and the total resistance is 0.025 Ohms, these can be replaced with 2x0.05 Ohms 2W each.

## Features

- Input 12V Lead Acid Battery
- Output Load Current up to 5A
- Low Battery Threshold 10.5V
- On Board Reset Switch
- On-Board Fault LED
- On-Board Output LED
- PCB Dimensions 53.18 x 32.86mm
- 4 x 3mm Mounting Holes

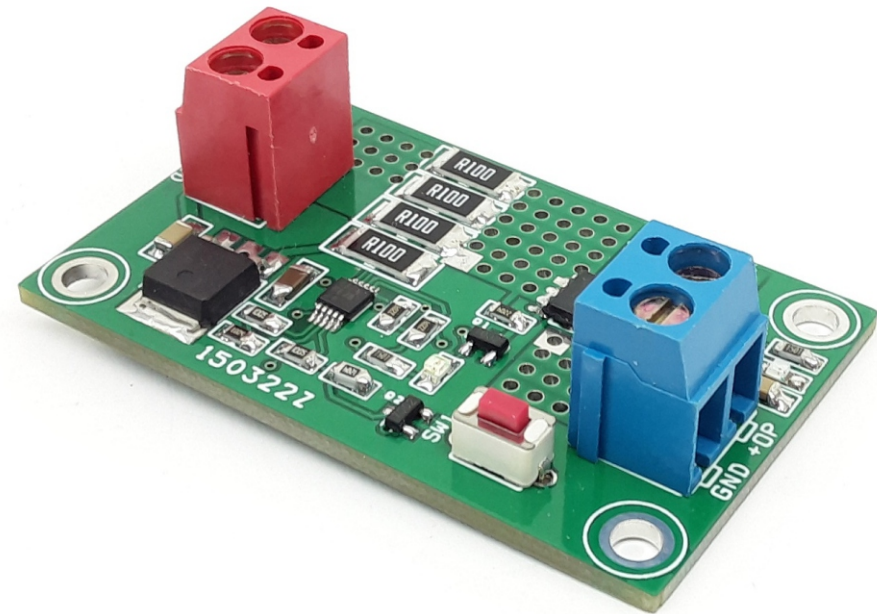

The circuit protects a lead-acid battery by disconnecting its load in the presence of excessive current (more than 5A), or a low terminal voltage indicating excessive discharge (< 10.5V). The battery and load are connected using 0.025Ω current-sense resistors (R1, R3, R4, R7) and P-channel power MOSFET U1. U1 can handle 30V of drain-source voltage and continuous current greater than 5A.

IC U3 is a micropower device drawing only 50μA of supply current. It contains a dual comparator and a high-side current-sense amplifier whose output current is proportional to the current through (R1+R3+R4+R7). The top comparator (C2) senses battery voltage via R2/R5, and drives COUT2 low when the voltage falls below 10.5V. That action turns on LED D2, turns off Q1, and allows R6 to turn off U1 by pulling its gate high. Thus, the battery load is removed when the battery voltage is less than 10.5V. Recharging the battery turns U1 back on automatically. C2's internal 1.5% hysteresis prevents output oscillation near the switching threshold. A linear regulator U2 provides a stable 5V for pull-up resistors R9 and R12. It also sources the 2.5mA required for fault indicator LED D2. LED D1 indicates the output power.

The output of latched comparator C1 is normally low, which turns off Q2 and allows normal operation. When a load current above 5A drives the CIN1, the voltage goes above 0.6V, the open-drain output COUT1 is latched high (open), allowing R9 to pull T2's gate high. The resulting low on CIN2 drives COUT2 low, disconnecting the load and illuminating LED D2 just as an over-discharge does, except the load remains disconnected until U3's active-low RESET input (normally pulled high via R12) is pulled to ground via the normally-open pushbutton switch SW1.



**Note 2:** Over current threshold can be changed by altering the value of current sensor resistors R1, R3, R4, R7 and R10, and R11.

## Connection and other Details

- CN1: Pin 1 Battery Red Terminal +12V, Pin 2 Battery Black Terminal GND
- CN2: Pin 1 + DC Output, Pin 2 GND
- D1: Output Power LED
- D2: Fault LED Over Voltage OR Over Current
- SW1: Reset Switch

# Schematic

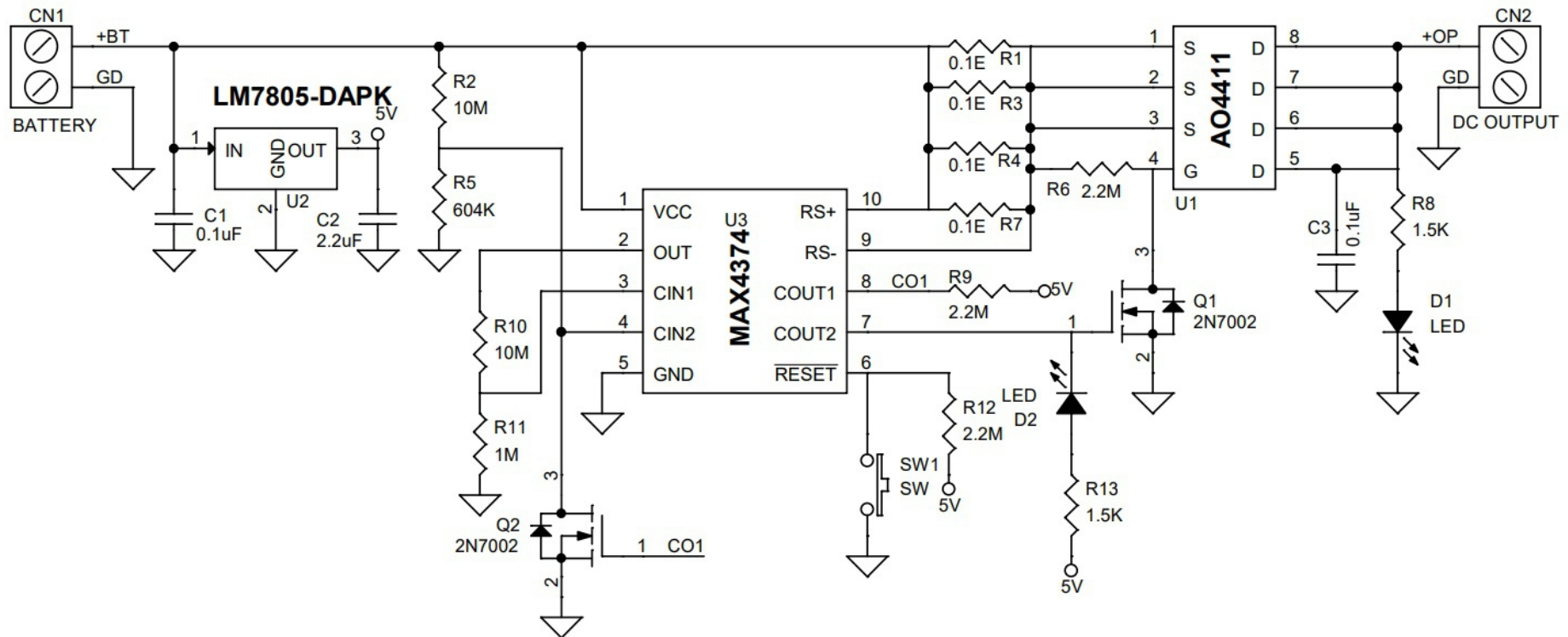

# Connections

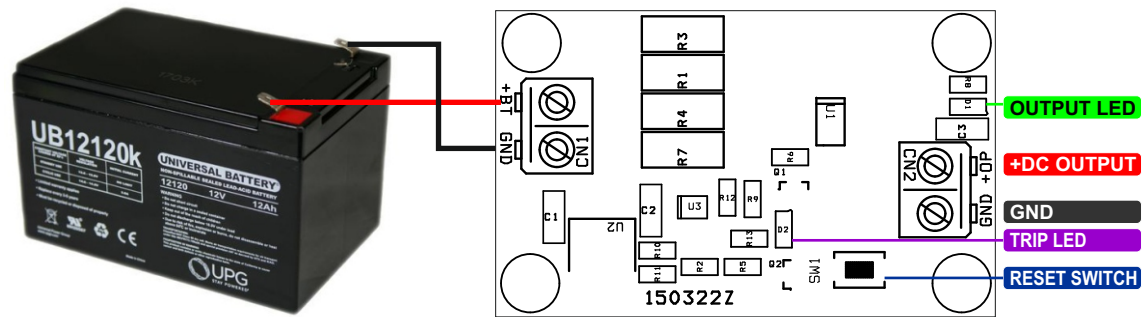

# PCB

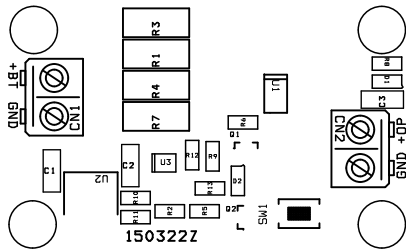
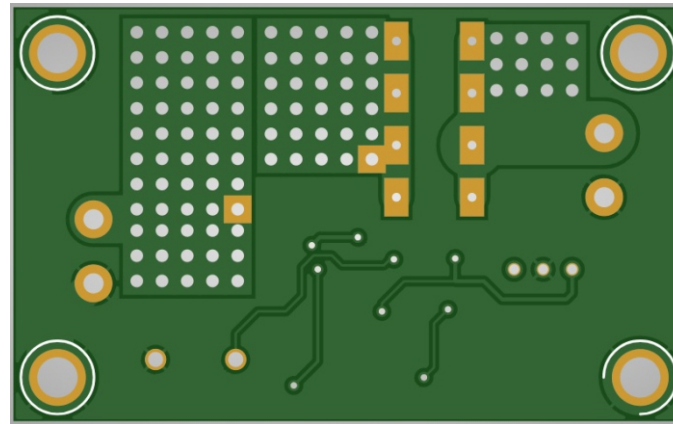
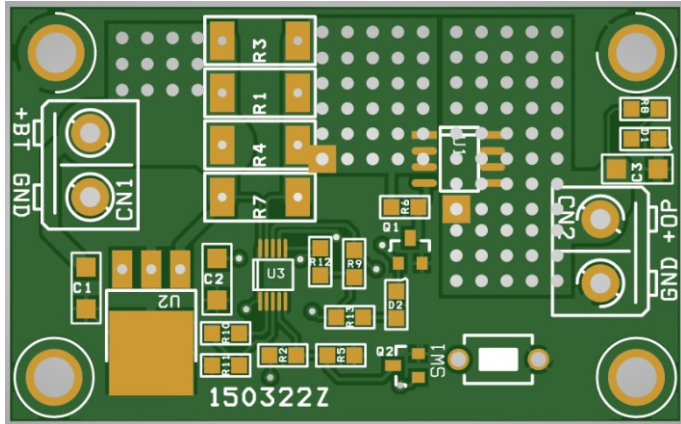

SILK SCREEN TOP

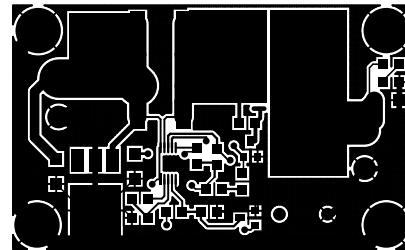

BOTTOM LAYER

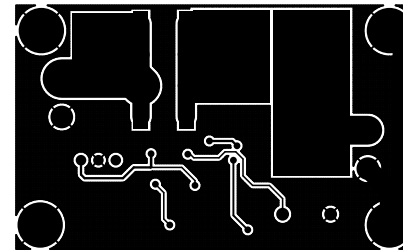

TOP LAYER

PCB DIMENSIONS 53.18MM X 32.86MM

# Parts List

---

BOM						
NO.	QNTY.	REF.	DESC.	MANUFACTURER	SUPPLIER	SUPPLIER PART NO
1	1	CN1	2 PIN SCREW TERMINAL PITCH 5.08MM	PHOENIX		277-1247-ND
2	1	CN2	2 PIN SCREW TERMINAL PITCH 5.08MM	PHOENIX		277-1247-ND
3	2	C1,C3	0.1uF/50V CERAMIC SMD SIZE 1206	YAGEO/MURATA		
4	1	C2	2.2uF OR 10uF/25V SMD SIZE 1206	YAGEO/MURATA		
5	2	D1,D2	LED RED/GREEN SMD SIZE 0805	LITE ON INC		160-1427-1-ND
6	2	Q1,Q2	2N7002 SOT23-3	DIODE INC		2N7002-FDITR-ND
7	4	R1,R3,R4,R7	0.1E/1W 1% SMD SIZE 2512	YAGEO/MURATA		
8	2	R2,R10	10M 1% SMD SIZE 0805	YAGEO/MURATA		
9	1	R5	604K 1% SMD SIZE 0805	YAGEO/MURATA		
10	3	R6,R9,R12	2.2M 1% SMD SIZE 0805	YAGEO/MURATA		
11	2	R8,R13	1.5K 5% SMD SIZE 0805	YAGEO/MURATA		
12	1	R11	1M 1% SMD SIZE 0805	YAGEO/MURATA		
13	1	SW1	TACTILE SWITCH 2 PIN	E-SWITCH		EG2513-ND
14	1	U1	AO4411 P CHNL MOSFET SOIC8	ALPHA & OMEGA		785-1284-1-ND
15	1	U2	LM7805-DAPK	TI		LM78M05CDTX/NOPBTR-ND
16	1	U3	MAX4374	ANALOG DEVICE		MAX4374HEUB+-ND





**Keep  
In touch..**

**electronics-lab**  
.com

info@electronics-lab.com  
www.electronics-lab.com

from ideas to **boards**

